

CT4040

Research to Sand-storage dams in Kitui district

Delft, August 2003

A.S. Burger, 9147030
W. Malda, 9540649
H.C. Winsemius, 9963060



Supervisors:

M. Ertsen (TU Delft)
W.M. Luxemburg (TU Delft)
S.A. Mutiso (SASOL)
J. Muinde (SASOL)

Preface

This report is written as a result of a part of the REAL project. The larger goal of the REAL project is to obtain a manual on how to organize water conservation in Arid and semi-arid lands (ASALs). This part of the project involves the scientific proof on the working of sand-storage dams, built by SASOL, a Non-governmental Organization (NGO) operating in Kitui district, East-Kenya. The first part of a long-term gauging program in Ngunga River (Kitui south) was set up during the research period. We were stationed in a community called Kisayani. Another project group has continued our work.

For guidance, support and making arrangements for our project from within Kenya, we want to thank Mr. S.A. Mutiso. For further guidance, help on technical details and organization from within the Netherlands, we want to thank Mr. M. Ertsen, mr. W.M. Luxemburg and Mrs. M. van Westerop. Special thanks for being part of the project, for sharing his geological knowledge with us and his translation work for us to the Akamba people goes to Joseph Muinde. Without him it would have been impossible to 'blend in' in Kisayani. Also we want to thank M.J.A.Hendriks and J.S. Kemerink for their stay together with us in Kisayani. Because of their stay, for us, our time was much more pleasant; the farewell party was unforgettable.

We will never forget how it was to live in the community Kisayani. In the end of our traineeship, we didn't feel guests anymore, we felt at home. Without the members of the community to cook, do our laundry or just chat with us, we would have had a much harder time.

H.C. Winsemius
A.S. Burger
W. Malda

Summary

SASOL is a local non-governmental organization (NGO) who is constructing sand-storage dams in the Kitui district since 1995. This area is one of the driest populated areas in Kenya, during dry months the water availability in some parts of this area can drop to zero. Sand-storage dams have proven to be the best solution in these kinds of areas, because of the relatively low costs per cubic meter of water. Since last year SASOL is cooperating with a project called Re-hydrating the Earth in Arid Lands (REAL), this project is founded to gain more knowledge in water conservation.

Although SASOL has already built over 300 sand dams in Kitui district successfully, there are still voices that claim otherwise. Many parties think that SASOL's activities do not contribute significantly to the water availability in the targeted areas in Kitui. Furthermore, potential participating communities are not convinced that the presence of a sand dam does not harm the water availability some distance downstream from the dam. SASOL needs proof to convince parties that series of dams bring more water to every community along a seasonal stream.

The objective of this part of the REAL project was to set up a gauging program that can prove that sand-storage dams work and do not harm water availability downstream from the dam. A study area in Kitui South in Ngunga River was selected for this purpose. SASOL has planned to build a dam here in July 2004, downstream from a present dam called Kamunyuni. A direct method to collect proof that sand dams work is a monitoring system for groundwater levels around the dam site that collects data before and after the dam has been built. An indirect method is the set up of a system that can provide a water balance in the catchment. This water balance should indicate that the water that is retained by the dam is significantly small compared to the water flowing over the dam. This, in combination with the extra amount of water which will be available for the downstream community after building of the dam from groundwater, and the fact that the dams are usually build in series, should convince these communities that the dams are in their benefit. Effectively the dams will improve the availability of water in time. This would indicate directly that the dam does not harm the water availability downstream.

To get more information about the study area, general information was collected with a desk study done in Kitui town. In the field, a baraza (community meeting) was held, which helped creating confidence and cooperation from the local communities. To make detailed mapping of the area possible a field survey was done. Important elements to collect are: the river profile, the condition of the river banks, the catchment area and the groundwater levels in the riverbed. The resulting map and the surface of the catchment are used to calculate the amount of inflow by rain in the studied river section. The groundwater gradient in the river proved that certain rock formations in the river section worked as natural barriers that often can be used as a foundation for a dam or as a direct water resource.

During this field survey one of the natural barriers turned out to be an alternative for the dam site proposed by SASOL. To be able to choose between the proposed site and the alternative location factors like rock depth, potential reservoir volume and water quality had to be investigated. Using a multi-criteria analysis, the proposed site turned out to be the better alternative. The most important advantages are that the banks are more suitable for infiltration and that the site fits best in the philosophy of series of dams.

For proving the functioning of the dam and quantifying the stored water volume, information on groundwater levels around the dam site was needed. Piezometers, made of PVC-tubes were used to obtain this information. Three cross-sections of piezometers were installed around the proposed site. Because of the presence of rock layers low beneath the surface or rocky soil the places to put piezometers were limited. Two cross-sections were installed upstream of the proposed site to investigate the influence of the dam upstream, one cross-section was installed downstream of the proposed site to investigate the water level differences. The water level differences can prove the working of the dam. The cross-sections were selected using criteria and

guidelines. A longitudinal section of piezometers is needed to estimate how far the influence of the dam reaches when it is silted up. This was not yet done during the time of study.

Soil research was done on soil samples to obtain the necessary soil characteristics (permeability and porosity) needed to do calculations on heads, measured by the piezometers. It proved to be very difficult to get reliable data on permeability and porosity. Therefore a better experiment should be used to determine these factors.

The water balance consists of inflow: over Kamunyuni dam and rainfall in the catchment; outflow: over the proposed dam site and by evapotranspiration; and storage. The water department Kitui supplied a rain gauge. This rain gauge was placed on the compound of the primary school in Kisayani. Rainfall over the area can roughly be estimated with measurements performed by the set up science club of the school. To obtain more accuracy on rainfall in the catchment more rain gauges should be installed in the area of interest. The parts of the water balance that are missing are flows over both dams and evapotranspiration.

Table of contents

Preface	1
Summary	3
Table of contents	5
List of figures	7
Figures in the appendix	8
Introduction	9
1 Background	10
1.1 Area of interest	10
1.2 SASOL Foundation	10
1.3 Sand dams built by SASOL	11
1.4 REAL project	12
2 Problem analysis	13
2.1 Problem definition	13
2.2 Objectives	13
3 Literary review	15
3.1 Groundwater mechanics	15
3.1.1 Darcy	15
3.1.2 Groundwater velocity	16
3.1.3 Bank infiltration and recharge storage	16
3.1.4 Reservoir volume	18
3.2 Water balance	19
3.2.1 Precipitation	19
3.2.2 Discharge measurements	20
3.2.3 Evaporation and runoff	21
3.2.4 Storage	22
4 Methodology	23
4.1 Collecting general information	23
4.2 Community approach	23
4.3 Field survey	24
4.3.1 River profile and gradient	24
4.3.2 Riverbanks	24
4.3.3 The Catchment	24
4.3.4 Groundwater level	25
4.4 Dam site investigation	25
4.4.1 Introduction	25
4.4.2 Rock levels	26
4.4.3 Reservoir size	27
4.4.4 Banks	27
4.4.5 Salt water	27
4.5 Installing piezometers	28
4.6 Soil research	30
4.7 Rain gauging	30
5 Results and findings	31
5.1 Field Survey	31
5.1.1 Introduction	31
5.1.2 River Profile	31
5.1.3 Catchment and side streams.	33
5.1.4 Geological/vegetation survey around the river	33
5.1.5 Groundwater levels	36
5.1.6 Possible dam locations	36

5.1.7	Conclusions	43
5.2	Groundwater	44
5.2.1	Soil characteristics	44
5.2.2	Piezometers	50
5.2.3	Collecting data	55
5.2.4	Conclusions and recommendations	55
5.3	Water balance	56
5.3.1	General	56
5.3.2	Precipitation	57
5.3.3	Discharge	57
5.3.4	Evapotranspiration	58
5.3.5	Storage	58
5.3.6	Conclusions and recommendations	59
6	Conclusions and recommendations	60
6.1	Conclusions	60
6.2	Recommendations	61
6.3	Continuation of the REAL-project	62
6.4	Recommendations for SASOL	62
	List of references	63
	Abbreviations	64
	Terminology	64
	Appendix I: Used equipment	67
1	Spirit level and staff gauge	67
1.1	Moving method	67
1.2	Rotation method	69
2	Augur	69
	Appendix II: Piezometers	70
1	Making piezometers	70
2	Plop devices	70
3	Calculation of heads	71
	Appendix III: Permeability and Porosity tests	72
	Appendix IV: Tables field survey	73
	Appendix V: Tables groundwater research	83
	Appendix VI: Rain gauge form	92
	Appendix VIII: Overview Ngunga River at the two locations	93
	Appendix IX: Map of Kitui south	945

List of figures

Figure 1: Organizational structure of SASOL	11
Figure 2: Sand-storage dam	11
Figure 3: flow through a confined aquifer	15
Figure 4: Piezometers with head and velocity	16
Figure 5: infiltration length with dam crest and dry and wet water levels with dashed storage (S) triangle and rock layer	17
Figure 6: Method of calculating the reservoir volume	18
Figure 7: Separation of the hydrograph, distribution in runoff	19
Figure 8: Explanation of the parameters used in the discharge formula	21
Figure 9: Baraza held at the introduction of the project in Kisayani	23
Figure 10: Catchment area	24
Figure 11: Dam site selection criteria and guidelines of SASOL	26
Figure 12: explanation of the reactions which create CaCO_3 and 'black iron'	27
Figure 13: Auger next to a piezometer	28
Figure 14: Criteria and guidelines for selecting cross-sections	29
Figure 15: level of the river around the kamunyuni dam and the proposed site	31
Figure 16: Length profile of the Ngunga River	32
Figure 17: Catchment	33
Figure 18: Vegetation study results around the river	34
Figure 19: Calculation of the reservoir volume at the Kamunyuni dam	35
Figure 20: Groundwater level and surface level of the Ngunga River	36
Figure 21: The area around the natural barrier, with the positions of the different augur sections	37
Figure 22: Augur Cross-section 1	37
Figure 23: Augur Cross-section 2	38
Figure 24: Augur Cross-section 3	38
Figure 25: Augur Cross-section 4	38
Figure 26: Augur Cross-section 5	39
Figure 27: Augur Longitudinal section 1	39
Figure 28: Area around proposed site	40
Figure 29: Augur Cross-section 6	41
Figure 30: Augur Cross-section 7	41
Figure 31: Augur Longitudinal Section 2	41
Figure 32: Model of the calculation of the K-values	45
Figure 33: Proposed site with positions of the different Piezometer Cross-sections	51
Figure 34: position of the different piezometers in piezometer Cross-section 1	51
Figure 35: Ground profile of piezometer Cross-section 1	52
Figure 36: Positions of the different piezometers in piezometer Cross-section 2	52
Figure 37: Ground profile of piezometer Cross-section 2	53
Figure 38: Positions of the different piezometers in Piezometer cross-section 3	54
Figure 39: The hydrological cycle	56

Figures in the appendix

Figure 40: Positive chosen direction and angles, seen from the reference point on Kamunyuni dam	67
Figure 41: Measuring falls between sections. The fall between the points A and B is five meters over the distance of two hundred meters. This is a fall of 2.5%. This figure also indicates that the fall is measured between two staff gauge locations.	67
Figure 42: Method of measuring angles, overview from above	68
Figure 43: spirit Level	68
Figure 44: spirit level for the width of the river	68
Figure 45: Tube with lid at both sides	70
Figure 46: Plop device in action	70
Figure 47: Calculation of the heads	71
Figure 48: permeability measuring	72

Introduction

Sand-storage dams are constructed by the local Non Governmental Organization (NGO) SASOL since 1992. The principle of sand-storage dams is not new, but some people doubt about the functioning of these dams and about the influence of the dams to river discharges. Therefore a long term research project is started with this report. The main part of this long-term project is gathering data of groundwater levels, rainfall and discharge.

This report gives the results of the first part of this project: the set up of the measuring program; the way that this set up is done and the installing process of the different parameters that should be measured.

In chapter 1 the background is given about the research project to Sand-storage dams: about the research area, about SASOL, about sand storage dams and about the real project.

Chapter 2 describes the problem analysis, which results in the objectives of the traineeship and of the project.

In chapter 3 a literary review is given to groundwater mechanics and the water balance. This chapter explains the theoretical, scientific background for the research. It's a theoretical summary, especially written for SASOL to have a clear theoretical overview. In this chapter also some theories are described, that are not used during the research. But these theories might be used in the future, for example the methods for measuring discharge in the river.

Chapter 4 explains the methodologies of all the methods that are used in the project, like the way of measuring the river profile, the measuring of the groundwater levels, the method used for rain gauging etc.

Chapter 5 gives all the results of the project. § 5.1 give the results of the field survey. § 5.2 give the results of the soil experiments. And § 5.3 give the results of the water balance.

In chapter 6 eventually the conclusions are drawn and recommendations are presented to the real project and to SASOL.

1 Background

1.1 Area of interest

Kenya is located on the equator along the East Coast of Africa. The country has approximately 30 million inhabitants. It can be roughly divided into 4 main zones: the coastal belt, the Rift Valley and central highlands, western Kenya and northern and eastern Kenya. Each zone has its own unique climate.

It is in the latter part, where Kitui district is located. It's located approximately 150 km east from Nairobi (number of inhabitants). Though some higher parts can be relatively wet, this district can be considered to be one of the driest parts of Kenya. It has two rainy seasons: March until April and November until January. Rain mostly comes in fierce showers. Most streams in Kitui district are seasonal. They all drain their water into Athi River, a perennial river that flows all through the year.

Kebwea sub-location in Kitui south is very dry. The area has few inhabitants compared to other parts of Kitui district. The area of interest here concerns Ngunga River, a seasonal river. The communities in the area have to face many problems concerning water. First of all, water is hardly conserved. Most water of the fierce showers runs off very fast on the mostly impermeable rocky and steep soils. Secondly, the amount of precipitation is very unreliable. Periods of extreme drought are common all over Kitui district. Finally, the timing of the rains is also very unreliable. The best moment to plant crops is hard to estimate. Bad timing of planting is mostly resulting in large losses and thus fewer yields.

Water conservation projects have been initiated by building so-called sand-storage dams, also called sand dams. The area of study is located in between a present sand dam, the Kamunyuni dam (finished April 2003) and a proposed location for a new sand dam, located approximately 1 km downstream from Kamunyuni dam. The new dam will be constructed next year. At the time of study, communities were in the process of building a new dam about 6 km downstream from Kamunyuni dam. This site is called Ngunga Kwoko. It proves that building activities in the area are increasing.

1.2 SASOL Foundation

SASOL stands for 'Sahelian Solutions'. "Sahel" is an Arabic word for dry lands. Thus SASOL means solutions to dry lands. It is a local NGO (Non-Governmental Organization) operating in Kitui district. It was founded in 1992. The main objective of SASOL was community development. However, this objective could not be achieved without water. Water is the starting point to development in ASALs (Arid and Semi-Arid Lands) like Kitui district. Therefore, water conservation is SASOL's mean of achieving their main objective.

Local communities are the starting points of SASOL's activities. It uses a bottom-up approach, which means that the communities identify their problem and provide the solution. SASOL is only a facilitator to the solution.

Originally, SASOL provided water to the people through construction of roof catchments with water tanks at schools and wells. Later, in 1995, they started the constructing of sand dams, which is now the main activity for SASOL. Their philosophy is to build a series of dams in a river to create bigger water availability. It has been able to build around 350 sand dams in Kitui district.

The organization of SASOL consists of a staff of about 30 members: the direction, field management and a group of artisans.

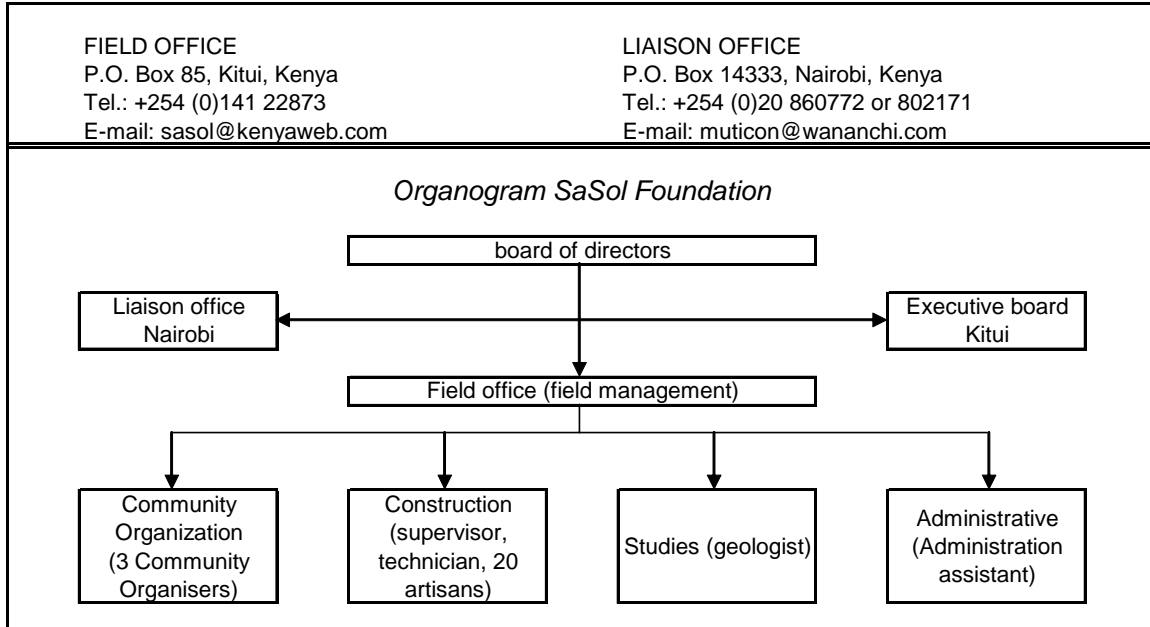

Figure 1: Organizational structure of SASOL

The activities of SASOL started in Kitui central and were expanded later on to Kitui west. In both parts they now construct sand dams in combination with shallow wells. Recently, SASOL also started working in Kitui south.

1.3 Sand dams built by SASOL

The idea of a sand dam is, to provide a sand bed in front of an artificial barrier that can conserve water in the form of ground water. After constructing a barrier out of local available materials on a suitable spot in a river reach, gradually the reservoir in front of the dam will fill up with sand. Depending on the sand load of the water, the filling process will take a certain time. In Kitui district, this is mostly around 4 years. This technology is not applicable, when the sediment load in an area is very small. The reservoir will fill up in the wet seasons thus providing water supplies for the dry seasons that can be exploited using scoop holes or shallow wells in the sand bed of the river.

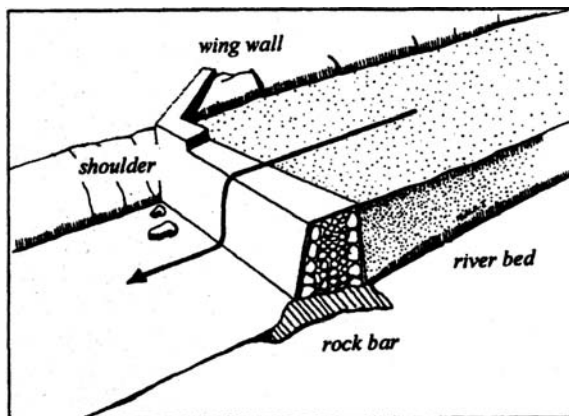

Figure 2: Sand-storage dam

A sand dam has several advantages. The construction is relatively cheap in comparison to other water conserving methods like roof catchments and boreholes. Also, the amount of water available in a reservoir is very large, especially when the riverbanks are permeable enough for infiltration and thus provide extra storage capacity. Because of these, the price of water per m³ is very cheap. Another advantage of sand dams is that when the reservoir is filled up with sand, the water can be considered groundwater, thus being bacteriological reliable as long as certain sanitary precautions are taken: there should be no contaminating sources nearby water providing sources like livestock droppings, latrines and wash facilities. And last but not least: surface water is a source of disease spreading organisms like malaria and bilharzia. Creating a sub surface reservoir prevents these illnesses from spreading.

Sand dams are not a new technology, they were already present during the colonial period. SASOL has adopted the technology because Kitui district is very well suitable for these dams.

1.4 REAL project

REAL stands for 'Re-hydrating the Earth in Arid Lands, Systems research on small groundwater retaining structures under local management in arid and semi-arid areas of East Africa'.

Delft University of Technology and Westerveld Conservation Trust established a network of universities and Non Governmental Organizations (NGO's) and with the help of the CICAT (Centre for International Cooperation and Appropriate Technology), they have succeeded in qualifying for a research and implementation fund of the European Union.

All the participating partners are shown in Table 1.

Principal Contractor	Related assistant contractor
Delft University of technology	Westerveld Conservation Trust (NGO)
SASOL (NGO)	University of Nairobi
University of Dar es Salaam	
IRC	
University of Leuven	Protos (NGO)

Table 1: Participation partners in the real project

The Rotary water harvesting project in Amboseli, along with the water projects in Kitui and Tsavo, will be used as a model for a manual about how water catchment structures in semi-arid areas should be organized and built. EU involvement is not only rooted in aid programs in so-called developing countries. The South European countries themselves also suffer from desertification and floods. In this the method that is in the process of development can be very useful.

2 Problem analysis

By experience, SASOL is aware that sand dams boost water availability. Studies on the social and economical impact of the dams have proven that many communities benefit from the dams. Instead of being dependent on scarce water resources far away and food supplies during famine, these communities can now often rely on their own resources.

In the last years, SASOL has made efforts to obtain scientific proof that the dams work. The Environmental Impact Assessment of Kiindu and Kyuusi rivers, done by SASOL and the University of Nairobi, has monitored and gathered data on the impact of sand dams in this area on vegetation and soils for the last 6 years. The results of 2000 and 2001 prove that, whether it is desirable or not, much perennial vegetation has been lost and replaced by annuals because of permanent water availability in the influence area of the dams. It has also proven that irrigation farming has been increasing in the years after the dams were built, which enabled farmers to change from subsistence food supply to cash crops. A geohydrological study by J. Muinde (SASOL) that was not finished during study tries to obtain proof on bank infiltration, a phenomenon that can result in a large amount of extra stored water in the riverbanks.

Nevertheless, the working of the dams and sedimentated reservoirs has never been quantified. Besides this, communities are hesitating in cooperating in the dam projects because they fear that a dam will diminish the water availability downstream.

As part of the REAL project, a gauging program is set up in the area of interest to gather more information on sand dams. The new dam downstream from the Kamunyuni dam and the catchment area around it will be used as a case study object to make it the most researched dam ever built by SASOL. Because professional gauging equipment is expensive, simple or borrowed materials should be used to provide gauging possibilities.

The resulting gauging system should make study on the dams possible that proves that sand dams work and don't influence downstream water availability. The research that will precede the system's installation will also give data on the depth of the rock formation that is used as a foundation for the dam. This will make pre-designing of the dam possible.

2.1 Problem definition

- There is inadequate scientific proof that sand-storage dams work properly.
- Community participation is affected by the fear of diminished water availability downstream of a proposed dam.

2.2 Objectives

Main objective

To design a long term gauging system to enable a scientific study into the functioning and performance of the sand dams

Outcome

The following things should be set up to achieve the objective:

- A system to study groundwater levels before and after the construction of the proposed dam
- A system to determine the water balance in the catchment through the formula:

$$Inflow(t) - Outflow(t) = \frac{\Delta Storage}{\Delta t} \quad \text{Equation 1}$$

- A database system to process the obtained data

- A new study that involves gathering the data provided by the gauging program

Justification

The gauging system should be able to determine:

- The difference in water levels in front and behind the dam before and after the construction including information about bank recharge by infiltration
- The water balance in the portion of the river between Kamunyuni dam and the proposed dam site after the construction of the latter, thus proving the functioning of the dams and determining the percentage of water conserved compared to the total flow

3 Literary review

In this chapter the theoretical background of the methods used and the calculations which have been made are explained. Theories and calculations for future activities in the project are also taken into account.

3.1 Groundwater mechanics

3.1.1 Darcy

Information about soil characteristics and groundwater levels can be used to describe the behavior of water in the upper aquifer of the reservoir and the banks on the side of the reservoir. The main principle used for this is Darcy's law, applicable in non-turbulent flows.

$$Q = kA \frac{dH}{dx}$$

$$Q = \text{Flow} \left(\frac{\text{m}^3}{\text{m} \cdot \text{s}} \right)$$

$$k = \text{permeability} (\text{m} / \text{s})$$

$$A = \text{surface per m} (\text{m})$$

$$\frac{dH}{dx} = \text{head gradient} (-)$$

Equation 2

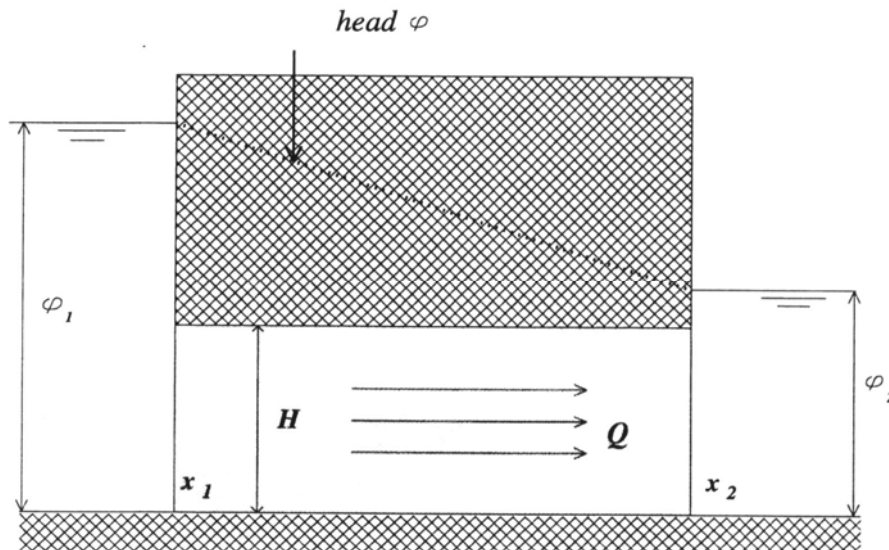

Figure 3: flow through a confined aquifer

3.1.2 Groundwater velocity

Darcy's law shows that the head gradient is the driving force for groundwater flow, which is linear dependent on it. The permeability determines the actual velocity through the soil.

When the gradient of the water table is considered linear between two piezometers, the actual velocity at a certain moment in time of the water flowing through soil (for example lateral into river banks or passing a dam as seepage) can be calculated with the following simplification of Darcy's law. Dividing by n gives the actual velocity because water can't flow through soil particles, only through pores.

$$v = \frac{k}{n} \cdot \frac{\Delta H}{L}$$

Equation 3

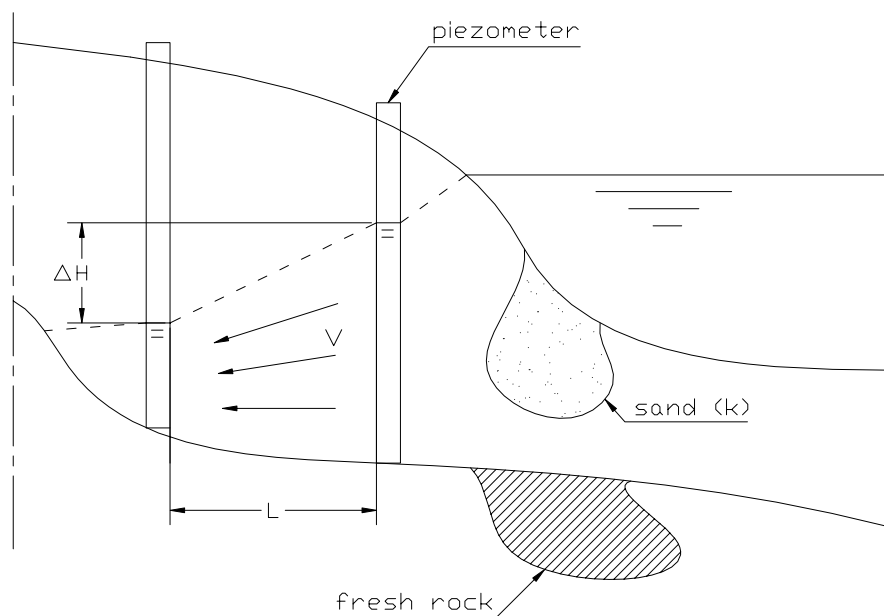

Figure 4: Piezometers with head and velocity

3.1.3 Bank infiltration and recharge storage

Applying Darcy's law, the *infiltration length* (L_t) in river banks upstream from a sand dam over a certain time-interval can be predicted. Certain assumptions have to be made to apply the following theory:

- The infiltration surface (A) includes: the bank where infiltration takes place, and: half of the riverbed.
- The soil characteristics (k and n) are uniform and known over the whole bank.
- The water level will 'jump' in a small time-interval (probably a couple of days up to a week in reality) to the height $H + \Delta H$ when the seasonal rains start. The height will be $H + \Delta H$ all through the rainy season.
- The theory holds until the infiltration length reaches the rock layer, see Figure 5. When the rock layer is reached, the water table should rise faster because the water can't go further bank inwards. Instead, this water will move further upwards.
- The rock is assumed to be impermeable.

- The rock is not very far in the banks. (approx. 50m) In reality, the gradient of the water level is not linear as is assumed in this method. The non-linearity will show when banks are wider.

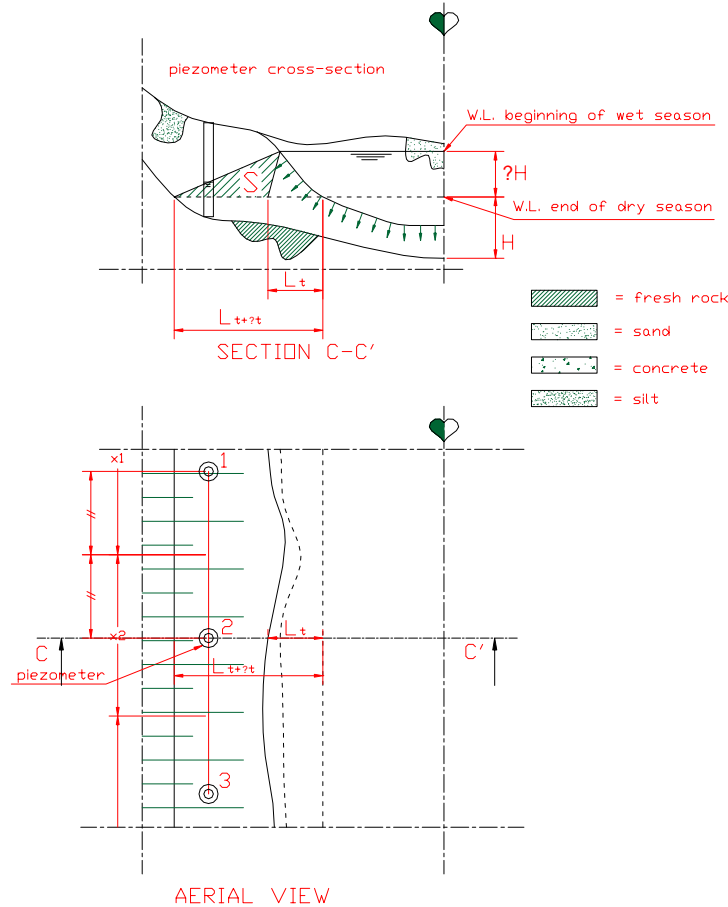

Figure 5: infiltration length with dam crest and dry and wet water levels with dashed storage (S) triangle and rock layer

Darcy's law integrated over a certain time interval gives:

$$Q\Delta t = kA \frac{\Delta H}{l} \Delta t \quad \text{Equation 4}$$

The volume stored (m^3/m) in this time-interval equals the surface of the dashed triangle multiplied by the porosity:

$$S = n\Delta H \frac{l_{t+\Delta t} - l_t}{2} \quad \text{Equation 5}$$

Because $Inflow = Storage$ the latter formula can be substituted in Darcy's law:

$$\frac{n}{2} \Delta H \frac{l_{t+\Delta t} - l_t}{\Delta t} = kA \frac{\Delta H}{l} \quad \text{Equation 6}$$

The latter can be written as an ordinary differential equation when $\Delta t \rightarrow 0$:

$$l \frac{dl}{dt} = \frac{2kA}{n} \rightarrow \frac{d(l^2)}{dt} = \frac{4kA}{n} \rightarrow l^2 = \frac{4kA}{n} t \quad \text{Equation 7}$$

The solution for l is then

$$l = 2\sqrt{\frac{kAt}{n}} \quad \text{or} \quad t = \frac{n}{4} \cdot \frac{l^2}{kA} \quad \text{Equation 8}$$

The amount of recharge storage (m^3/m) is equal to the surface of S . When infiltration length and rock profiles and soil characteristic are known over more cross-sections (c-s) (m), the total volume of water caused by recharge can be calculated:

$$V_{recharge} = \sum (S_m \cdot x_m \cdot n_m), \quad \text{or when the porosity is everywhere the same:}$$

$$V_{recharge} = n \sum (S_m \cdot x_m) \quad \text{Equation 9}$$

3.1.4 Reservoir volume

The c-s's of rock levels and water levels in the studied river section must be known perpendicular on every piezometer in the longitudinal section. An estimation of the reservoir volume can be made as follows:

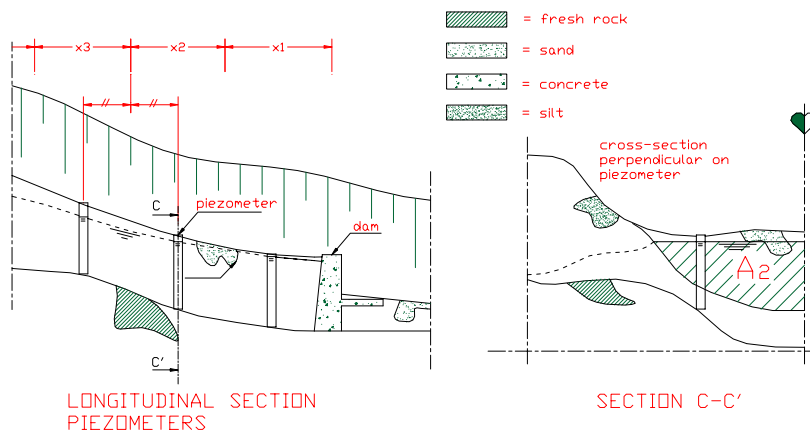

Figure 6: Method of calculating the reservoir volume

By calculating the saturated sand surface in every known c-s (m), multiply it with the length (x_m) of the reservoir part that this c-s represents (see figure.. for meaning of x_m) and with the average porosity of the sand in this reservoir part. The total reservoir volume is obtained by summing up all the parts calculated in the previous step. This results in the following formula:

$$V_{reservoir} = \sum (A_m \cdot x_m \cdot n_m) , \text{ or when the porosity is everywhere the same:}$$

$$V_{reservoir} = n \sum (A_m \cdot x_m) \quad \text{Equation 10}$$

3.2 Water balance

3.2.1 Precipitation

Obtaining reliable precipitation data requires a rain gauge network. The amount of samples of rain taken in the area determines how accurate the resulting rainfall data is. Rain measurements of different samples can be combined using interpolating methods such as inverse distance method or Thiessen polygons (see *W.M.J. Luxemburg et al (January 2003) – CT4440, Hydrological measurements, Lecture notes*).

The amount of rainfall that finds its way to the river is called the *effective rainfall*. The way effective rainfall of a shower runs off to the river depends on the characteristics of the rainfall (duration, intensity and direction of the shower), topographic factors (slope of the catchment, vegetation cover) and geological factors (soil types, rock formations). A *hydrograph* shows the time distribution of this runoff, dividing it in *base flow* and *surface runoff*.

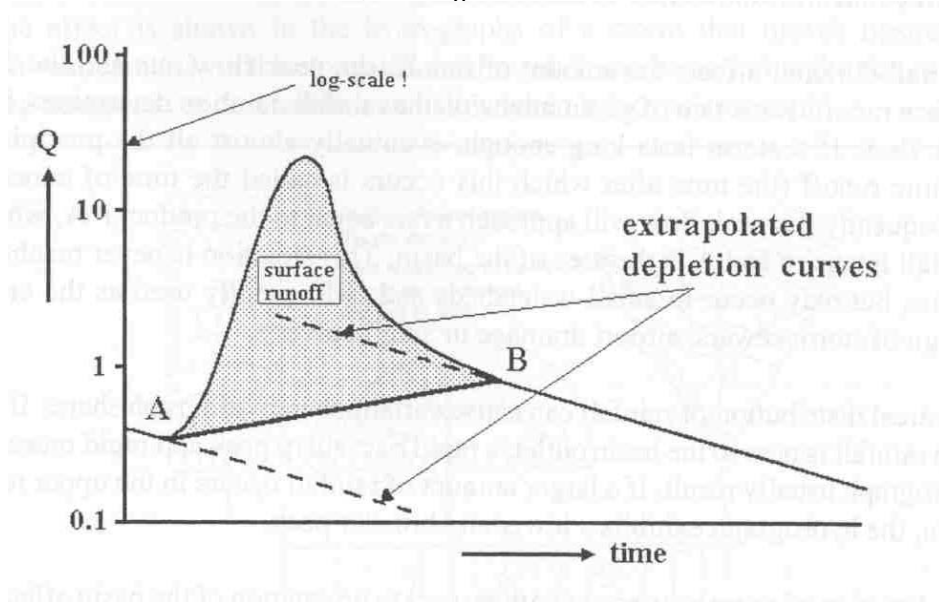

Figure 7: Separation of the hydrograph, distribution in runoff

The *surface runoff* is considered dominant in the area of interest because of the many rock layers and steepness (practically all the effective rainfall will runoff immediately, there is no percolation to soils). The *base flow*, through groundwater flow is considered small or even negative. This would mean that the river is influent.

3.2.2 Discharge measurements

Measuring (dam)structures

The spillway of a dam can be used as a measuring structure. The reservoir level above spillway level is required. When this level is monitored it is possible to determine the discharge-time relation over the dam's spillway. It can easily be measured, by installing a staff gauge next to the dam and read it every certain time-interval (for example 0.5 hours) while there is discharge over the dam.

The general equation for discharge over a spillway is:

$$Q(h) = C.b.h^{3/2}$$

Q = discharge

C = discharge coefficient

Equation 11

b = length of the dam

h = height of the water table just in front of the dam

The spillways of dams are not always rectangular. Especially with sand dams, often non-rectangular spillways are observed. The exact parameters in the discharge formula are dependent on the form of the spillway (see for guidelines *W.M.J. Luxemburg et al (January 2003) – CT4440, Hydrological measurements, Lecture notes*)

Dilution gauging

Dilution gauging is, however based on a simple principle, a delicate method to obtain discharge information. To a constant unknown discharge Q in the stream, a smaller constant discharge ΔQ that consists of a salt-solution with an exactly known concentration ϕ_1 is added. ϕ_0 , the concentration on a location further downstream where complete mixture has taken place, is measured. Using mass balance, Q is calculated using the following formula:

$$\phi_0 = \frac{\Delta Q}{Q} \cdot \phi_1$$

ϕ_0 = constant concentration

ΔQ = discharge of injection

Equation 12

Q = discharge of river

ϕ_1 = measured concentration in river

Slope area method

The *slope area method* can be of use to estimate the maximum discharge during a flood. After a flood has occurred, flood marks will be present in the riverbanks, such as mud on rocks or floating debris in trees. These should be marked using paint. As many marks as possible should be gathered.

For the computation, a straight reach of about 10 times the width of the river should be chosen: no sharp bends, islands, pools, constructions or rapids should be present. The computation should be done on 5 to 10 cross-sections in the reach.

Combining the found flood marks with the width in the river reach, the dimensions of the cross-sections can be approximated. They can be used in the following calculation:

$$Q = CA\sqrt{RS}$$

Equation 13

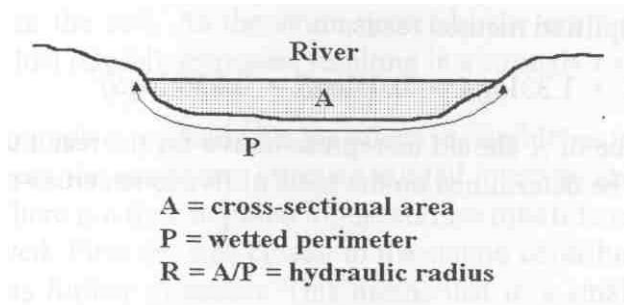

Figure 8: Explanation of the parameters used in the discharge formula

Note: the slope area only calculates the *maximum* discharge. People in the area should inform about the duration time of the flood. The total volume that passed the computed cross-sections is hard to estimate with this method.

3.2.3 Evaporation and runoff

To estimate the amount of water leaving a catchment by evaporation and transpiration a study on vegetation and meteorological parameters is needed in the area of interest. A computer model can be created in for example CROPWAT. The following parameters are needed:

- Min. and max. temperature (°C)
- ET_0 and ET-crop values of crops and vegetation present (mm/day)
- Humidity (percentage)
- Sunshine (hr)
- Wind speed (km/day)

A remark should be made about the use of evaporation. The amount of evaporation (E) equals the amount of rainfall that will not come to runoff (R) in a certain catchment.

$$E = (1 - C_r)R$$

Equation 14

C_r is the runoff coefficient. Evaporation is mostly considered as a loss. However rainfall that falls in the Sahel is for a very large proportion (more than 90%) supported by evaporation from areas nearer to the coast (proven by Hall and Savenije (1995)). The average number of times that a water particle is recycled land inwards equals:

$$n_{recycled} = \frac{1}{C_r}$$

Equation 15

This means that evaporation is not a loss. On the contrary: it is a recycle-process. Water that runs off directly to sea is not transported further land inwards. Therefore direct runoff to the coast can be considered a loss. A series of dams in a river catchment can conserve water which therefore stays in the area.

3.2.4 Storage

$$Inflow(t) - Outflow(t) = \frac{\Delta Storage}{\Delta t} \quad \text{Equation 16}$$

In *Equation 16* the definition of storage is given as a derivative of time. The net amount of storage can either increase (when net inflow is positive) or decrease (when net inflow is negative) over Δt : the amount of storage fluctuates in time. $\Delta Storage/\Delta t$ is very hard to quantify. Mostly exact quantification is impossible. However, if the *account period* Δt is taken sufficiently long, the storage becomes certain orders of magnitude smaller than in- and outflow. In due time it becomes negligible, because precipitation, evaporation, and discharge accumulate but the storage only varies within a certain range. Often Δt equals a *hydrologic year*. It starts on a moment that storage does not vary a lot. Just before the rainy season starts is a good moment. If a whole year is considered a too long period for research, Δt can also be taken one rainy season. $\Delta Storage$ can be significantly larger then. It's probably advisable to use the long rainy season as research period in this case.

4 Methodology

In this chapter the methodology of the gathering of the necessary information is described, the results which were obtained by this methodology are described in chapter 5, 'Results and Findings'.

4.1 Collecting general information

From the TU Delft maps of the area were collected which gave the first impression. These maps are shown Appendix IX: Map of Kitui south.

To get information about the project area, general information was collected in a desk study, done at the Kitui *District Information and Documentation Centre* (DIDC). This information involved meteorological reports done between the years 1961 and 1981 by Louis Berger International Inc. & Wanjohi consulting engineers under supervision of the government. The study was done to give the general hydrological information of Kitui district. After 1981 however, the gauging system put in place stopped operating.

Discussions about sand dams, the project area and the content of the research were held. It helped in designing a methodology suitable for the project area and getting the necessary equipment before going to the field.

On the site, a reconnaissance study to familiarize and choose the exact study site was carried out by walking along the river reach in between the two built dams, Kamunyuni and Ngunga Kwoko. The proposed dam site was passed approximately 1 km downstream from the Kamunyuni dam.

4.2 Community approach

For familiarization with the local communities, to tell them what was going to be done in the area and to get permission to work on neighbouring shambas (agricultural lands), a *baraza* (community meeting) for the Kebwea sub-location was held.



Figure 9: Baraza held at the introduction of the project in Kisayani

This enhanced cooperation from the local community and gave enough confidence to work in the area. It was also important because the installed systems left behind to maintain data collection should be red out by the community in absence of REAL students or SASOL personnel. Their participation in the project was imperative. Involving them also prevented curiosity and made them aware of the importance of the project for dam investigation. Translation from English to the local language Kikamba and back was an important element in the *baraza*.

4.3 Field survey

4.3.1 River profile and gradient

To relate the river profile in the topographic map of the area, a spirit level and a staff gauge were used. The data collected in this survey were the angles in degrees for river turns using the compass of the spirit level, the gradient of the riverbed by measuring the fall in meters, the length of the measured sections in meters and the width in meters. To measure this data, a reference point was chosen at the Kamunyuni dam. The dam provided a good reference point because it is easily recognizable and will not move in time. An explanation of the use of the spirit level is given in.

4.3.2 Riverbanks

Characteristics of the riverbanks in the area were studied to determine sections that were suitable for research. The sections had to be suitable for placing piezometers and researching bank infiltration possibilities. The characteristics investigated included height and steepness of the banks, vegetation cover and geological formations marking the banks. This was done by observation.

4.3.3 The Catchment

To determine the area of influence between the Kamunyuni dam and the proposed site, the water divides of the area were mapped using an *Etrex summit* GPS. The water divides were defined by all the gullies flowing to the side streams joining the river between the Kamunyuni dam and the proposed site thus taking the topographic divides as borders.

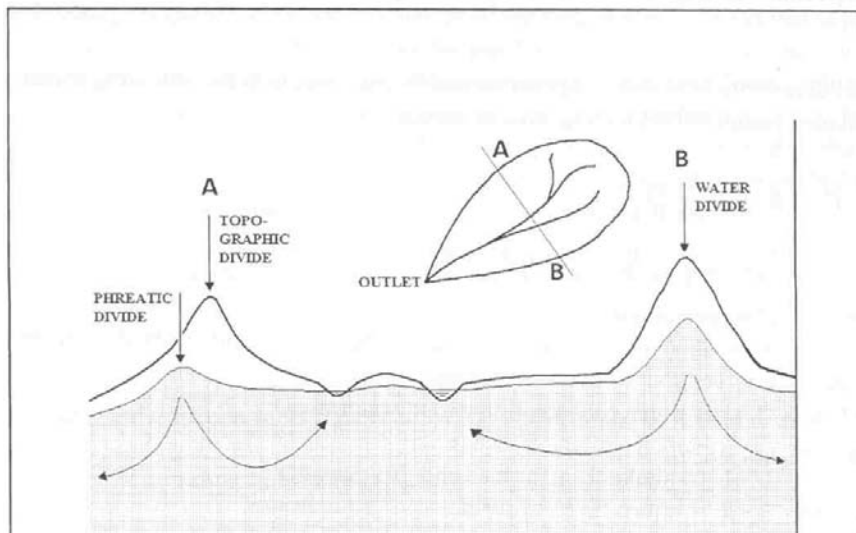

Figure 10: Catchment area

This was done by walking along the topographic divides while taking global position at the apexes of the divides. The points taken were then plotted in a map made of the area. These points connected made the catchment area. The portions that were not accessible due to steepness or too thick bushes were inferred from the known points.

4.3.4 Groundwater level

To determine the groundwater levels in the river profile, a spirit level, staff gauge and a manual augur were used. Small holes were drilled into the soil until groundwater was reached. Fall of the groundwater level and the fall of the surface level were measured simultaneously at the same point. Both surface and groundwater levels were plotted in one drawing. This was done to relate the groundwater levels to the surface level along the river profile at a certain moment in time.

4.4 Dam site investigation

4.4.1 Introduction

During the field survey there were still possibilities for shifting the proposed dam site. Further research on the dam site was important, because it determined the location of the groundwater research and it influenced the size of the catchment area. Therefore research was done on possible dam locations in the surrounding of the proposed site. From experience, SASOL has developed criteria and guidelines for dam site selection that are used after the communities have accepted and approved to participate in a sand dam project. To the 12 criteria, as shown in on the next page, the following criteria were added:

- The depth of the rocks in the banks upstream of the dam location: the deeper the rock, the larger the reservoir volume
- Does the location fit in the philosophy of creating bigger water availability by building a series of dams?
- Water quality: how is the water quality at the upstream side of the site

Using these criteria, two possible locations were chosen for further investigation:

- A natural barrier, approximately 200 m upstream from the proposed site.
- The proposed site

For the investigations, on both sites two new reference points were taken, thus creating a reference line on both locations.

1. Enough local materials must be present. Water, needed for the construction must be available in a maximum radius of 1 km.
2. At least 30 households must be participating for 2 reasons:
 - There is more labour power available.
 - More people benefit one dam. This enlarges cost-effectiveness. Cement makes the largest expenses.
3. The site must be easily accessible. Mostly a dam downstream, close to a road is best.
4. Riverbanks must be suitable:
 - Banks must be high enough: at least 1.5 meters to prevent the construction from being too large.
 - Soil must be firm enough. Soft soil needs large wings to stabilize the construction. Based on experience, SASOL uses 7 meter wings for soft soils (only if there are no other possible locations) and 5 meter for firm soils.
5. Scoop holes provide an indication of present natural barriers. Scoop holes that dry up during the dry season are considered good locations for a dam. 'Wet' scoop holes already provide water all through the year. This information is obtained from users.
6. Reservoir volume: Gradient and recharge possibilities are used as an indication of the volume of a reservoir. A smaller gradient makes a larger reservoir, also more recharge will increase the volume of the reservoir.
7. Risks of bypass: A dam can't be built in a bend since this will cause bypasses.
8. A possible natural barrier can be used as foundation for a dam. Note: there are risks of seepage when the rock is not impermeable. Scoop holes upstream that dry up very fast after the rainy season are suspicious.
9. There must be enough inflow (in mainstreams, this is never a problem).
10. Soil in banks: Kunkar limestone and Black Cotton Soil (BCS) have the habit to cause piping very easily because the soil flushes out or dissolves (kunkar limestone).
11. The location should be at least 3 km away from an earlier built dam because of social aspects:
 - Certain communities might get more water than needed when dams are too close to each other.
 - Water sources will be too far away for certain communities when no attention is paid to the allocation.
12. The river must flow from time to time:
 - To provide water for storage.
 - To provide a sand load to fill the reservoir in front of the dam.

Figure 11: Dam site selection criteria and guidelines of SASOL

4.4.2 Rock levels

One of the site selection criteria mentions the presence of a rock layer. However, although SASOL is almost every time certain about the presence of a rock layer, there is mostly no information about the depth of this layer. Auguring at possible sites could determine easily how deep the rock layer was at both sites.

Several indicators suggest the presence of a natural barrier. Mostly there is a fall in the water table over the section. Or there is a decreasing gradient in the water table from upstream to the barrier. Scoop holes upstream of the barrier with a high water table throughout the year can also be an indicator. By auguring on the possible barrier location the actual presence of a barrier can be proven.

4.4.3 Reservoir size

For comparing the reservoir sizes of the possible dam locations the guidelines 4 and 6 of SASOL were used. See site selection criteria and guidelines in .

4.4.4 Banks

Heights of banks and soil types in the banks were taken into account thus using SASOL's guidelines 4 and 10. See site selection criteria and guidelines in .

4.4.5 Salt water

Another consideration for site selection could be the salt concentration of water. Mostly sophisticated equipment like a conductivity meter is necessary to test the water on salinity. Though this equipment was not available during the study, some indicators of salinity could be pointed out:

- Goats are licking saline rocks. They like the salt.
- The local community did not use the water for drinking.
- CaCO_3 is present
- The soil produces 'black iron'

A chemical explanation with the reactions is shown in Figure 12

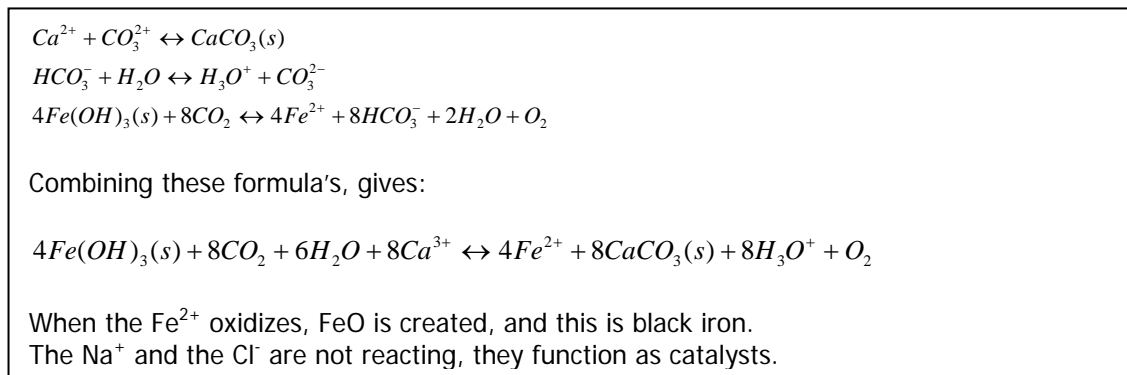

Figure 12: explanation of the reactions which create CaCO_3 and 'black iron'

Although a high salinity of the water does not necessarily mean that a location is not suitable, the water can't be used for certain purposes, especially drinking. Because of all the other functions like life stock drinking, washing, cooking and cleaning, SASOL doesn't use this consideration as a criterion.

4.5 Installing piezometers

For measuring groundwater tables, piezometers are used. The piezometers, perforated PVC-tubes, were installed using an augur.

This was done in several cross-sections along the river course. The cross-sections of piezometers were installed to be able to measure groundwater levels upstream and downstream of the dam, before and after the construction. Because the cross-sections were extended into the banks, it is also possible to monitor bank infiltration with the upstream cross-sections when certain soil characteristics like permeability and porosity are known.

The water levels in the tubes can be measured with a plop-device that was made using very simple materials. For a description of and manual on how to use the plop-device, see Appendix II: Piezometers

The inability of the augur to drill and the suitability of the banks limited selection of cross-sections. The selection was based on several criteria and guidelines that are mentioned in Figure 14:



Figure 13: Auger next to a piezometer

1. Allocation

- The cross-sections must be in the neighbourhood of the dam site.

2. Soil characteristics

- In the cross-sections auguring must be possible. Depending on the type of soil auguring is or isn't possible:
 - Fractured rock in the banks is not suitable for research because auguring in this material is impossible. Furthermore, the amount of water present in the layer is hard to determine. There is actually bank infiltration but one can't determine the amount nor study the location because auguring here is impossible.
 - Fresh rock: It can't be studied but one can assume that there is no water table present. When it's possible to augur in at least one of the banks (the soil is clay, silt or sand) then the cross-section is suitable.
 - Weathered rock: In a certain phase, weathered rock can be so soft that auguring becomes a possibility. When this is the case, weathered rocks in the banks make a suitable cross-section. If not, the banks are unsuitable for investigation purposes.
 - Clay and silt: In these soil types auguring is possible. Even below groundwater level auguring is possible. Placing piezometers with high groundwater table is no problem.
 - Sand: In this soil type auguring is possible, but only above groundwater level. Placing piezometers with high groundwater table is not very useful, because piezometers might become useless most part of the year, due to lower groundwater levels, then at the time of installing.

3. Banks

- The banks must not be higher than approximately 2,5 meters above the riverbed. This is because the used augur cannot reach a larger depth than approximately 4 meters. Groundwater levels should be measurable to up to 1,5 meters below the riverbed. Beneath 1,5 meters groundwater levels are too low to measure in the worst case.
- Banks with lots of bush are not suitable. Roots and obstructing shrubs and trees make auguring impossible. Even when auguring succeeds, it might be hard to find the piezometer back in a later stadium. Especially near shambas, one should be careful with clearing the bush. They are often used as fences to prevent cows and goats from coming on to the shamba and destroy crops.

4. Riverbed

- A strait reach is desirable, because the choice of a cross-section perpendicular on the riverbed will then be easy. It is however not an absolute necessity. SASOL mostly chooses a straight reach for a dam location so mostly this should not be a problem.

5. Practical indicators

- Permission of landowners is needed to use a certain cross-section.
- Animals must not trample piezometers. They must not be placed on cattle or foot paths. Small shrubs might provide some protection against animals.

Figure 14: Criteria and guidelines for selecting cross-sections

The cross-sections and surroundings were mapped using the rotation method, (see Appendix 1.2, Rotation method). The reference points used were related to the original reference points, chosen at the dam sites. The data collected with this method was the morphology of the riverbed in the direct surroundings of the cross-sections, the allocation of the piezometers, the height of the surface level at these locations and the height of the rim of the piezometers. The latter two are necessary to relate measured lengths of the wire on the plop-device to a reference height.

4.6 Soil research

The goal of soil research is to obtain values for permeability and porosity of different soil layers and to determine the composition of these layers. This information, together with groundwater gradients (obtained by piezometer measurements) can be used for several quantifications, like groundwater velocities between tubes, seepage and infiltration length from the river into the banks.

Samples were collected from the augur holes where piezometers were installed and that are likely to be saturated with water when the dam has been built. The procedures for determining the porosity and the permeability in the study are described in Appendix III: Permeability and Porosity tests

The depth of soil layers in the chosen cross-sections were determined by observation. The change of soil layers could be seen in the augur. The depth from surface level at which a new layer was found was documented.

4.7 Rain gauging

From a desk study, it was established that, between the years 1961 and 1982, a meteorological study was done in Kitui district supported by the Kenyan government. Precipitation data and even some discharge data (on one location) were obtained. During these programs, an enormous amount of data was gathered. The data proves that the average amount of rainfall in a year in Kebwea sub-location was about 625 mm. Two rain gauges were present near Kebwea: gauge 9138013, located at Ikanga chiefs camp and 9138051, located at Enzou primary school. Since 1982, no data has been gathered. This story proves that rain gauging is possible in Kitui. Because the data collected is from twenty years ago, bearing in mind that the climate changed, the data can only be used to compare with the new data. It cannot be used as input in the research.

Part of the inflow in the water balance comes from precipitation. Recent rainfall data is not available. Therefore a rain gauge was arranged from the hydrological department of the DIDC in Kitui. It was installed and should still be present in the research area.

Criteria for the placing of a rain gauge are:

- The top of the rain gauge should be at least 300 mm above the surface level to avoid water from splashing in.
- The top of the rain gauge should not be higher than 1.5 meters. At this height the wind might influence the catch.
- Animals must not have direct access to the rain gauge.
- No obstacles should be present nearer than five times the obstacle height.

To avoid loss of the catch by evaporation daily readings are necessary. Therefore an institute or organization is needed which is prepared to read the gauge daily. Possible institutes are a police station, a school or a hospital.

5 Results and findings

5.1 Field Survey

5.1.1 Introduction

The first phase of the research was the field survey. The methods used in the field survey phase are explained in chapter 4.3, Field survey and in. Different aspects in the field survey are:

- Measuring the river profile
- Measuring the catchment area
- A geological and vegetation study
- Measuring groundwater levels in the river
- Investigating different dam locations

5.1.2 River Profile

The profile of the river is measured with the Spirit Level from the reference point at the Kamunyuni dam downstream to the proposed site. The following characteristics of the river were determined.

- Gradient
- Morphology
- Width

The tables with the data of the river profile characteristics can be found in Appendix IV: Tables field survey. Two figures are made: a map of the area with the length profile of the river and a map with the fall of the river. The fall of the river is shown in Figure 15. The profile of the river is shown in Figure 16. The curved lines in this figure give the sides of the river bed. The straight lines give the measuring direction.

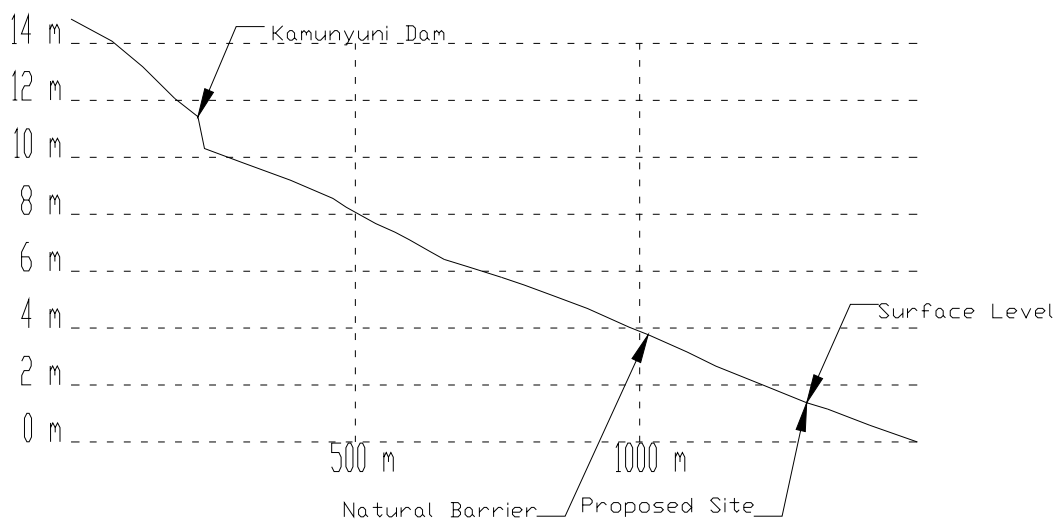

Figure 15: level of the river around the kamunyuni dam and the proposed site

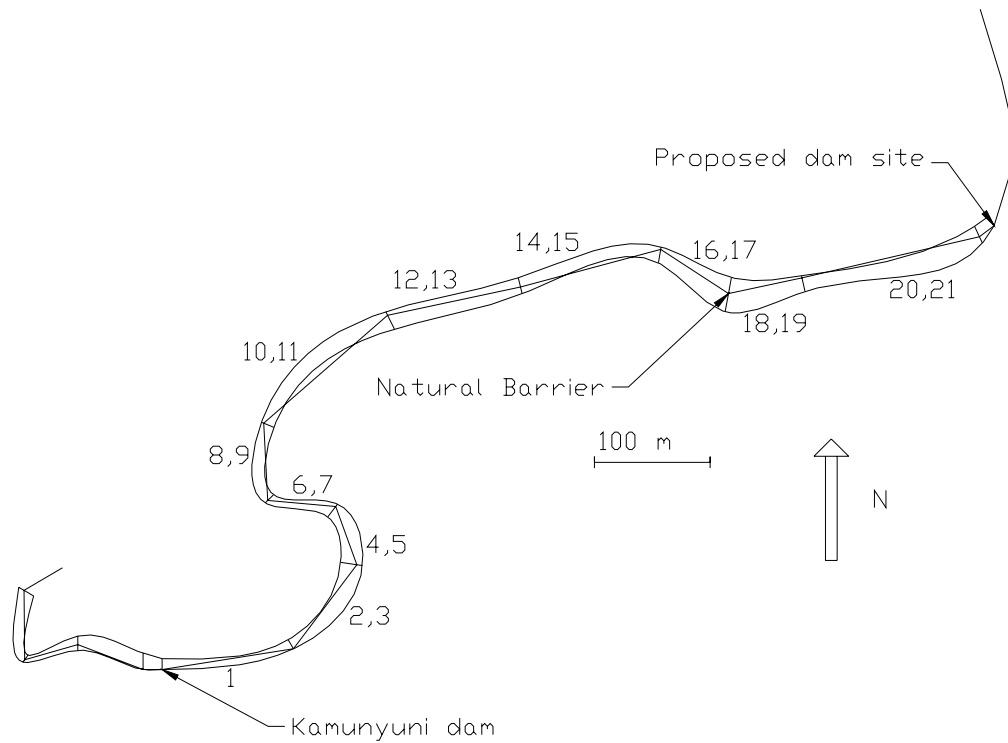

Figure 16: Length profile of the Ngunga River

The information on morphology can be used in dam site allocation: as mentioned in §4.4.1, straight reaches are suitable for dam sites. A small gradient provides a large reservoir. In most parts of the river, the gradient was approximately 1%. The width can also be used for determining dimensions in a discharge calculation using *slope area method*.

5.1.3 Catchment and side streams.

The size of the catchment area (A) is determined to be approximately 1.5 km². This size is necessary for obtaining the precipitation volume in the catchment. Combined with the rainfall data (P), the volume of rain (V_{rain}) over a certain account period Δt can be calculated using the following formula:

$$V_{rain}(\Delta t) = A \cdot P(\Delta t)$$

Equation 17

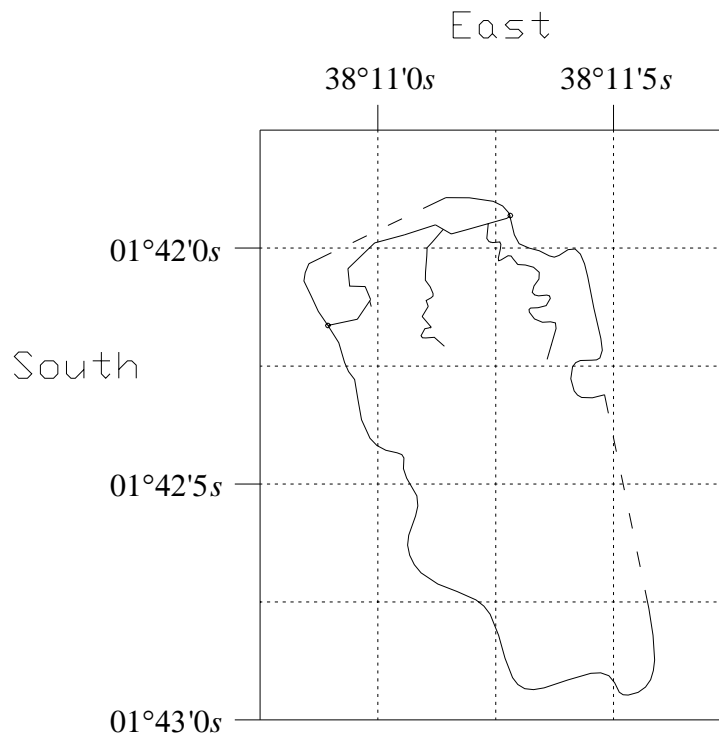

Figure 17: Catchment

GPS positions of the catchment area are in Appendix IV: Tables field survey. The catchment area is drawn in Figure 17

5.1.4 Geological/vegetation survey around the river

The area lies in the mozambican belt of the basement system. Oblique dipping units of highly weathered and fresh granitoid gneiss/hornblend biotite species overlain by tertiary sediments and some sedimentary rock units characterize the region. Kunkar limestone is also occasioned in the area resulting from weathering of the incubent gneisses in the area. The fresh gneisses in the area are either massive or highly fractured. Bank infiltration is thus quite minimal in them and the only possibility is in the fractures. In the portions with weathered gneiss, bank infiltration is evident. Water table is found through auguring. Thus in these areas it is possible to install piezometers.

The area is also characterized by the presence of deep soils that grade from top sandy loam soils to silty and then clayey soils. These are considered to be a result of alluvial quaternary deposition. Rock geochemistry plays a great role in determining both the water quality and soil characteristics.

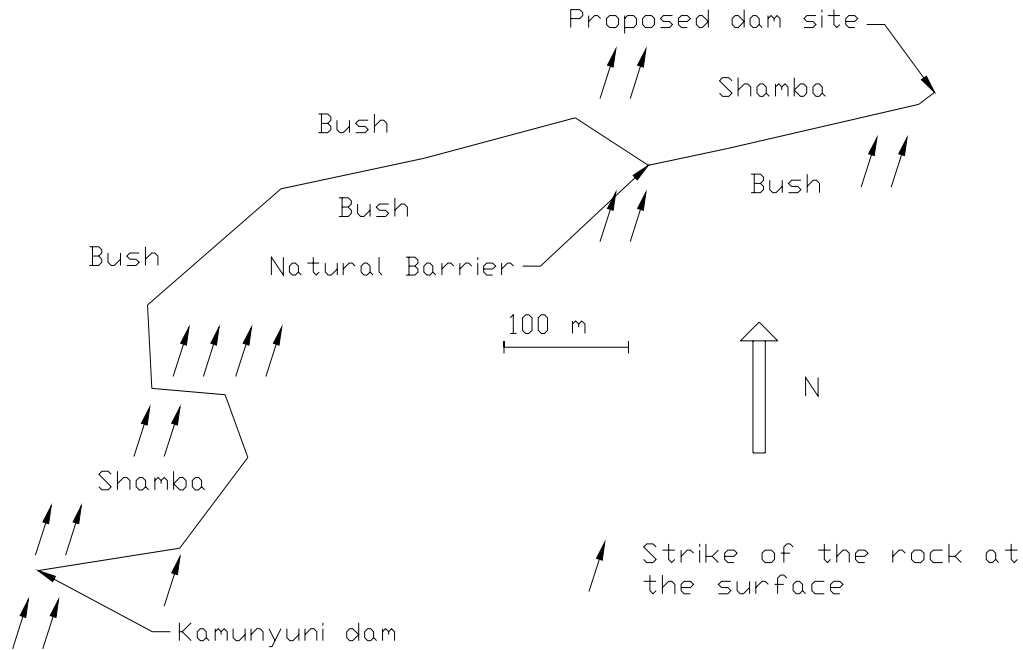
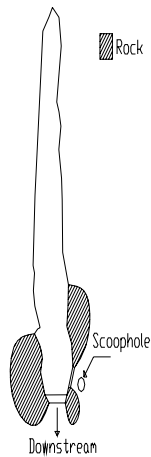

Figure 18: Vegetation study results around the river

Vegetation plays a great role in determining potential water tables in the river course. Different plant species signify presence of a high water table. There are prototype trees found at the banks of the river, which indicate high water tables in some portions of the river, which are determined by auguring. In Figure 18, the results of a global field survey are drawn in the map of the river profile.

Source: J. Muinde, SASOL (June 2003)



Reservoir Area Kamunyuni dam

Case study: In the field survey some research at the Kamunyuni dam was done.

The first thing done is extending the crest level to the surface of the reservoir. Using the rotation method, the future reservoir area is obtained; this reservoir is showed in the figure above.

The second part of the investigation is looking for possible cross-sections for installing piezometers. No locations were found because of rock close beneath surface level. The results of the augurings are shown in Appendix V: Tables groundwater research in Table 13. Combining the fact that nearly everywhere rock was found very near under the surface with the fact that the gradient of the river at the upstream part from the Kamunyuni dam, as shown in the figure above, it can be concluded that the reservoir volume of the Kamunyuni dam is relatively small and bank recharge will hardly occur due to fresh rock layers directly bank inwards. The dam construction however was easy to build.

Figure 19: Calculation of the reservoir volume at the Kamunyuni dam

5.1.5 Groundwater levels

The study on the levels of groundwater showed that the levels dropped immediately downstream from the Kamunyuni dam.

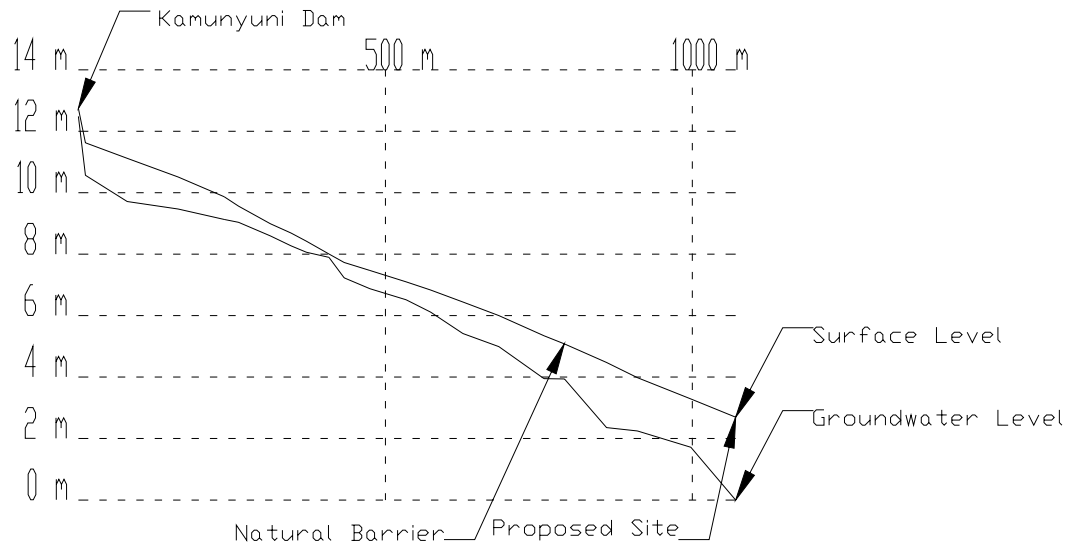

Figure 20: Groundwater level and surface level of the Ngunga River

The water level is clearly not parallel to the surface level. Rock formations form natural barriers across the river, thus forming subsurface reservoirs. This causes the variations in the groundwater level gradient. A nearly horizontal level followed by a considerable fall in water level indicates the presence of such a barrier under the surface. The natural barrier can either be used as a possible dam location or as an element in a series of dams.

5.1.6 Possible dam locations

The two possible dam locations studied showed differences in their suitability for dam sites. Much preference was given to the proposed dam site. This was after determining the depth of the rock, the width of the river, the water quality, suitability for bank infiltration and the morphology of the river. Availability of scoop holes also guided the selection of the sites.

A detailed map with the both locations in one map can be found in Appendix VIII: Overview Ngunga River at the two locations

Natural Barrier

In the natural barrier, it was found out that the depth of the rock was less than one meter (see Figure 22 and Figure 27.). The width of the river at this spot was 50 m. Upstream from the natural barrier, the subsurface water in the sand was saline. The left bank was quite high with highly saline rocks. The right bank was low and very flat with rocks close to the surface. No scoop holes were present upstream of the natural barrier. The location was at a bend of the river. A map of the area around the natural barrier is shown in Figure 21. The places of the different longitudinal- and cross-sections are marked. In Figure 22, Figure 23, Figure 24, Figure 25 and Figure 26 the different cross-sections are shown. In Figure 27 a longitudinal section is

shown. In Appendix IV: Tables field survey, the following tables in relation to the natural barrier can be found:

- Table 15 is the data of the area around the natural barrier, using the rotation method,
- Table 16 - Table 20 gives the data of the longitudinal sections and the cross-section.
- In Table 21, the data of the measuring of the reference points at the natural barrier in accordance to the reference points at the proposed site are shown.

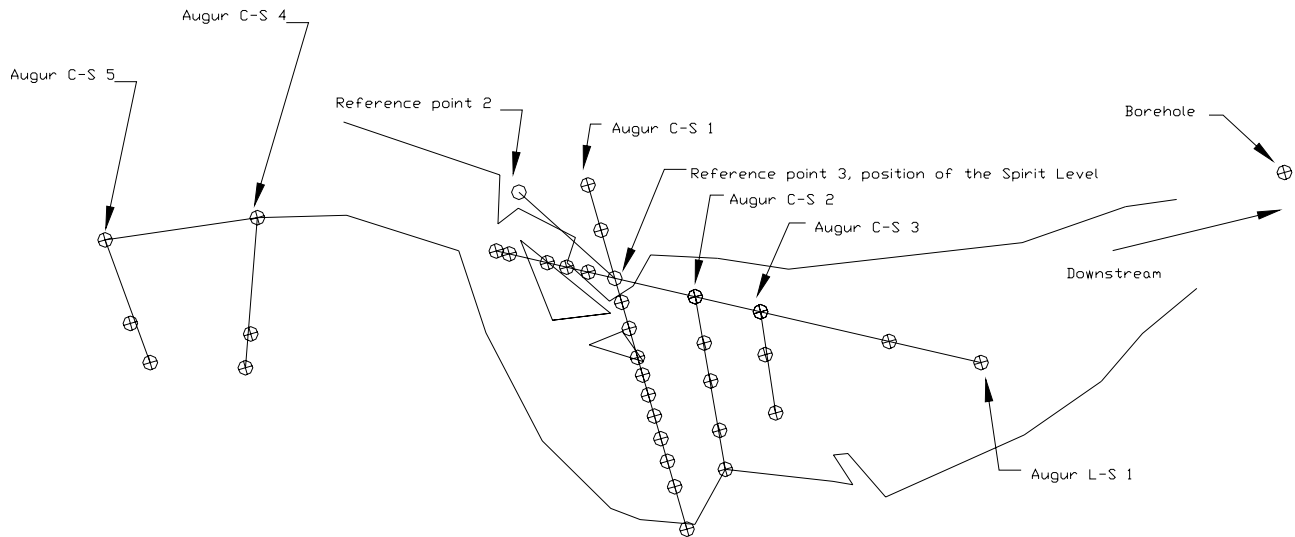

Figure 21: The area around the natural barrier, with the positions of the different augur sections

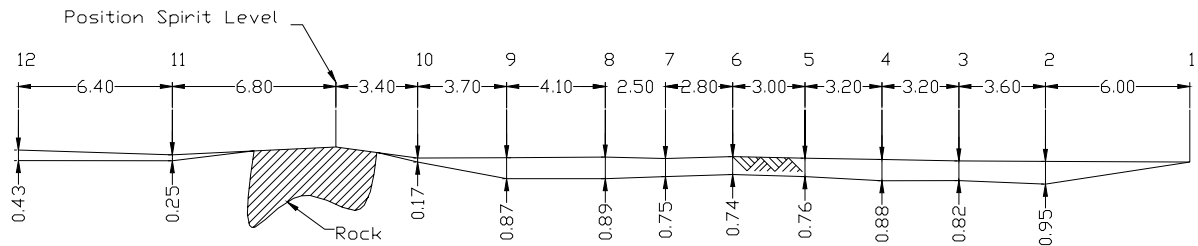

Figure 22: Augur Cross-section 1

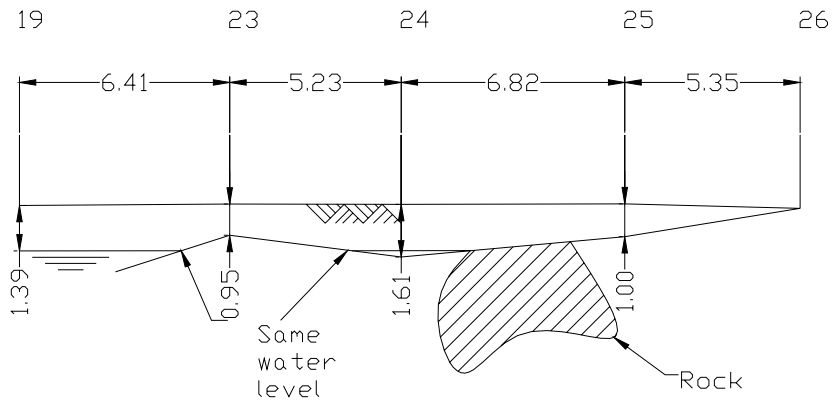

Figure 23: Augur Cross-section 2

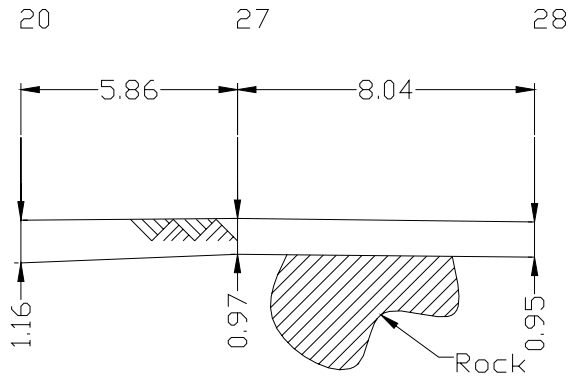

Figure 24: Augur Cross-section 3

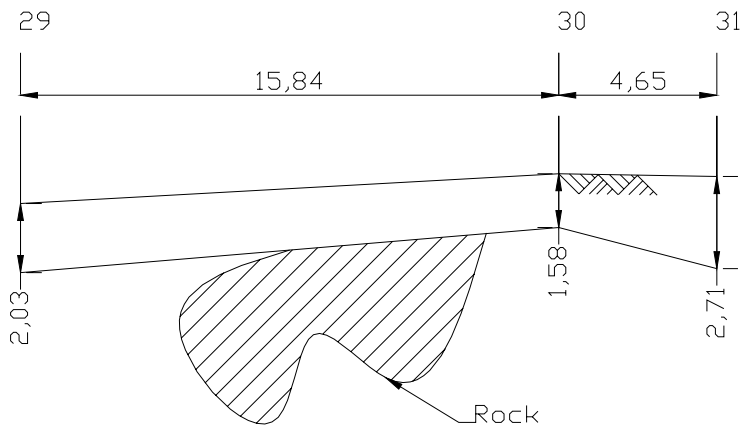

Figure 25: Augur Cross-section 4

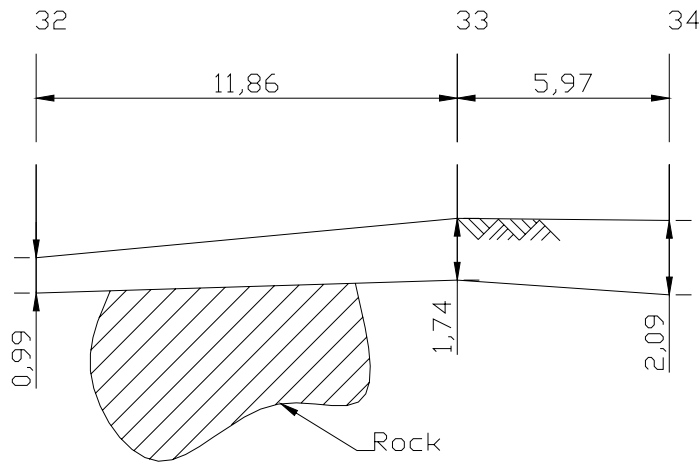

Figure 26: Augur Cross-section 5

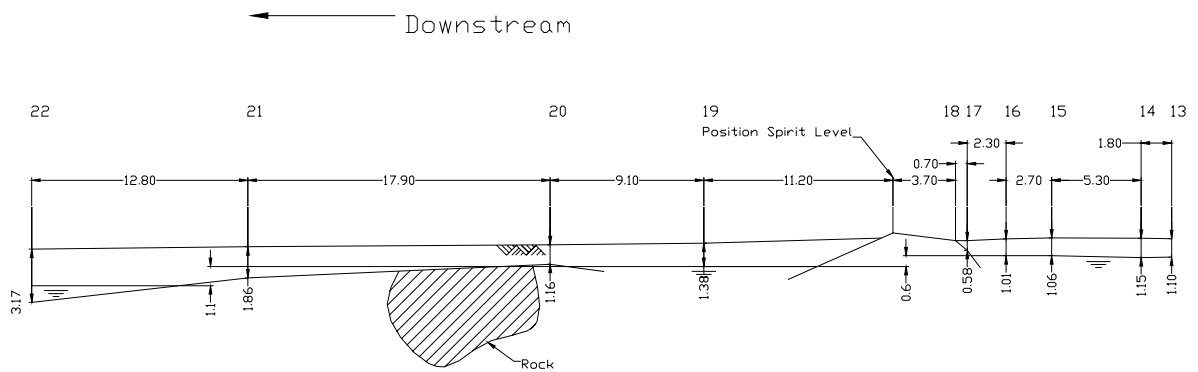

Figure 27: Augur Longitudinal section 1

Note: From Figure 20 can be concluded that there is another natural barrier upstream from the one that is researched. The groundwater level upstream of this barrier reaches almost to the surface. According to the local farmers the water in this reservoir is saline. Indicators as described in §4.4.5, such as licking goats where found here. This water is only suitable for cattle, laundry and production of bricks.

Proposed Dam location

The proposed dam site is marked by presence of a rock outcrop in the right bank. This rock however is not crossing the river bed surface. It is about 2-2.5m deep in the ground and this depth is extending into the left bank. The river channel is about 10 m. across at the site. The site is in a straight reach of the river. Upstream, the nearest corner is about 200 m. The left bank consists of soft silty soils, which are deep to a maximum of 4.6m beneath the surface.

In Figure 28 the map of the area around the proposed site is shown, the places of the different cross- and longitudinal sections and the reference line.

The tables with the data from the auguring and the rotations method can be found in Appendix IV: Tables field survey. The different cross-sections and longitudinal sections are showed in Figure 29 - Figure 31.

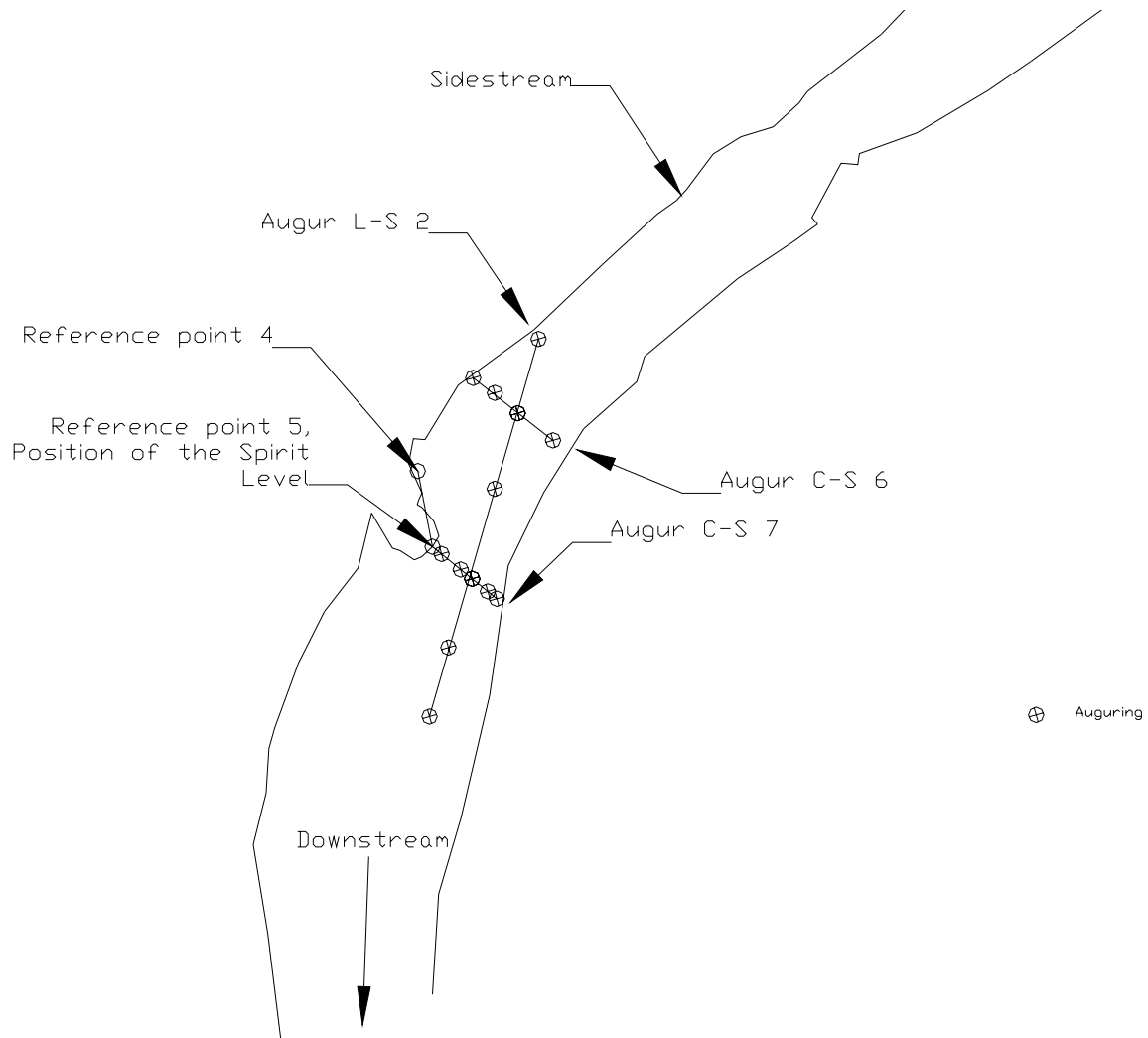

Figure 28: Area around proposed site

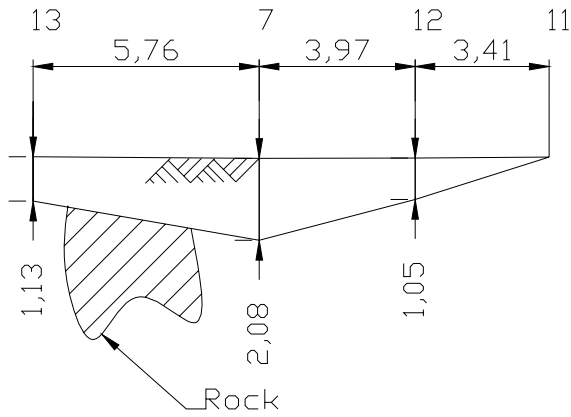

Figure 29: Augur Cross-section 6

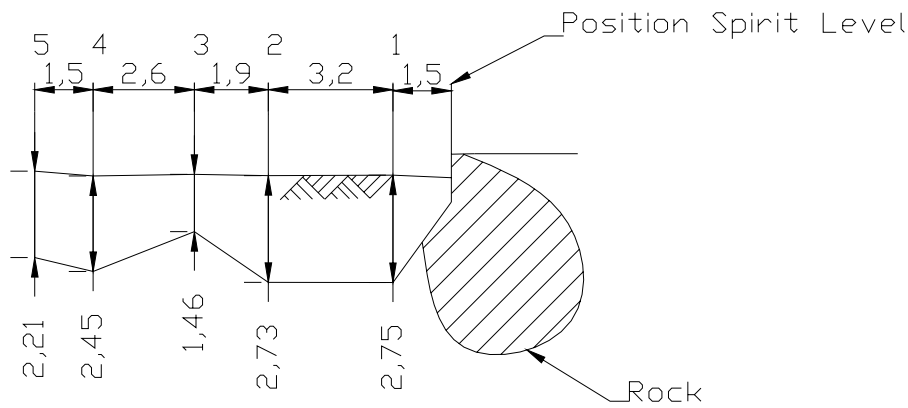

Figure 30: Augur Cross-section 7

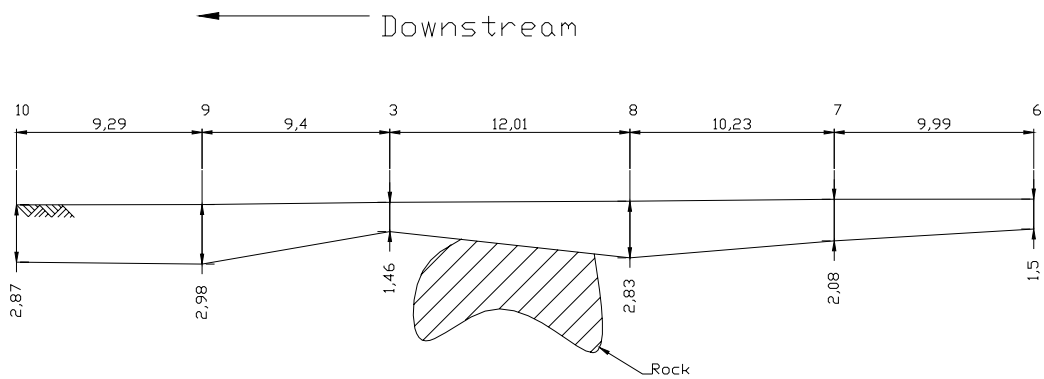

Figure 31: Augur Longitudinal Section 2

Comparing the two sites

The two dam sites can be compared on different criteria. Because of the importance of the dam site for the project, a choice has to be made. To make the decision-making easier, a multi-criteria-analysis is used. This multi-criteria-analysis is shown in Table 2: Multi criteria-analysis on dam sites

By giving scores to the two alternatives, the difference can be emphasized. By giving weights to the criteria and multiply them with the scores the difference can be calculated. The last column indicates which criteria determine the difference in the decision making.

Nr.	Criteria	Natural barrier	Proposed site	weights	Natural barrier	Proposed site	N-P
1	Local materials present	++	++	7	14	14	0
2	participating households	0	0	5	0	0	0
3	Access to site	0	0	5	0	0	0
4	Suitable riverbanks	+	+	6	6	6	0
5	Not drying scoop holes	+	+	3	3	3	0
6	Big reservoir volume	+	+	9	9	9	0
7	Risk of bypass	++	++	9	18	18	0
8	Foundation possibilities	++	+	6	12	6	6
9	Amount of inflow	0	++	2	0	4	-4
10	Type of soil in the banks	+	+	4	4	4	0
11	At least 3 km from dam	--	-	3	-6	-3	-3
12	Stream appearance	+	+	8	8	8	0
13	Depth of rocks in banks	-	+	6	-6	6	-12
14	Creating series of dams	0	+	9	0	9	-9
15	Water quality	-	+	3	-3	3	-6
	TOTAL	7 +	14+		59	87	-28

Table 2: Multi criteria-analysis on dam sites

Conclusion of site study

The multi criteria analysis in Table 2 shows that the proposed site is the better alternative. It scores 28 points higher than the natural barrier. The difference is caused for the bigger part by the depth of the rocks in the banks and the series of dams. The depth of the rock in the banks is determining the amount of recharge and part of the reservoir volume. The series of dams indicate the benefit in water availability of the alternatives. It is obvious that with the natural barrier the increasing in the water availability will be smaller comparing to the proposed site.

5.1.7 Conclusions

- The proposed site is the better alternative for building a sand-storage dam.
- Dam site allocation is better of with a good field survey.
- Information about the width of the cross-sections is necessary to determine the construction efforts. This width can also be used in calculating the discharge using the slope area method.
- The gradient of the river is one of the most important factors in determining the reservoir volume.
- Presence of fresh rock makes foundation easy and shortens the construction period.
- Auguring is an easy method to determine the depth of the rock layers.
- Pre-design is necessary to determine the depth of the foundation, the construction time and therefore the cost efficiency.
- Groundwater varies in the riverbed, variation in vegetation indicates this.
- Rock formations across the river can behave as natural barriers. They can either be used as dam site foundation or as an element in a series of dams.

5.2 Groundwater

5.2.1 Soil characteristics

Permeability

For determining permeability (k), each time efforts were made in getting 6 samples for testing in the experiment set up. This was done to obtain more accuracy in the value of permeability. Samples were taken from several places in the aquifer. It was obligatory to use samples from soil layers were saturation and thus groundwater flow was expected.

During testing some advantages and disadvantages of the used experiment are suspected. The advantages were that the experiment was easy to set up. Mostly local materials (except the PVC-tube) were used. The experiment is suspected to lack on the following points:

- Materials to obtain compact soil samples from the depth necessary were unavailable. Therefore stirred samples were taken out of the augur on the wanted depth. They were inserted in the tube and compacted using a stick. The soil was not saturated when taken from the aquifer. Therefore the soil was saturated before testing started. Because of these inaccuracies, the characteristics of the soil samples were never equal and it was unknown how close to reality the testing was.
- Due to adhesive forces on the tube, the water might have been slowed down thus resulting in lower k -values
- The coarse material used for draining the water might have clogged during testing thus resulting in lower velocities and lower k -values
- The holes in the bottom got clogged during testing thus resulting in lower velocities and lower k -values

Because of this, every obtained k -value should be treated with suspicion. Because sand is mostly compact as it is, the expectation is that the results for sand are the best. The resulting graphs in ln-scale are presented below. Every graph mentions the type of soil and place and depth where the soil was taken from.

More layers of soil give a combination of k -values. This stratification can be modeled as one k -value (ir. R.H. Boekelman et al 2002)

$$k_h = \frac{\sum_{m=1}^n k_m d_m}{\sum_{m=1}^n d_m}$$

Equation 18

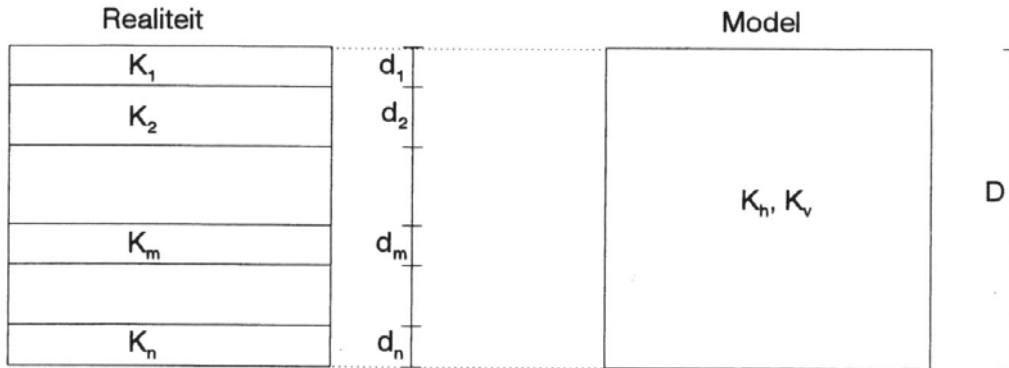
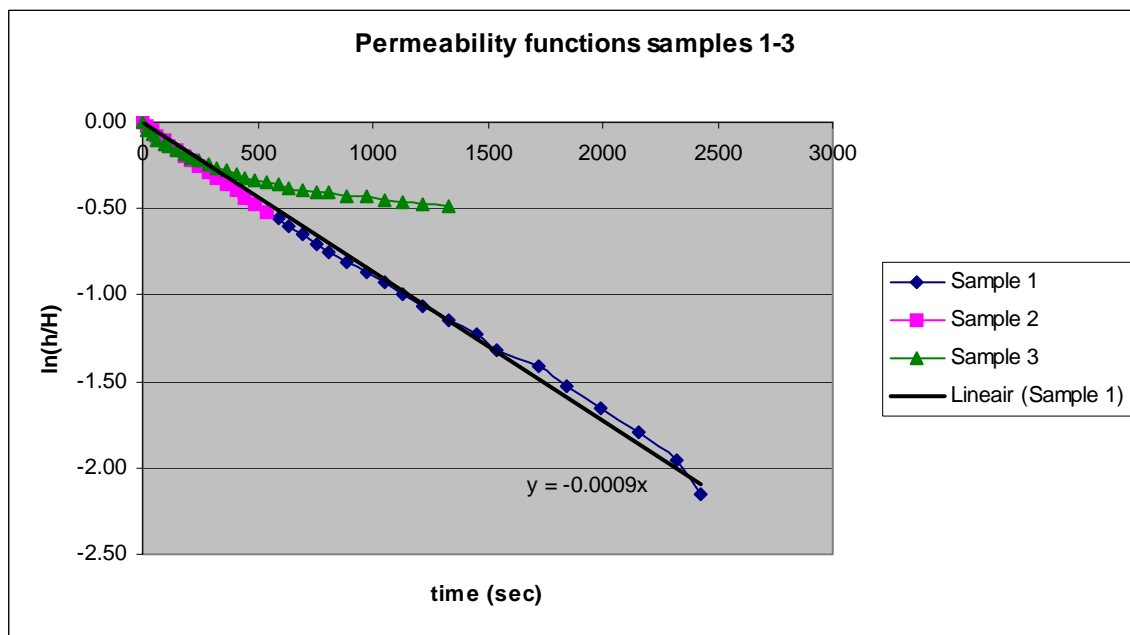
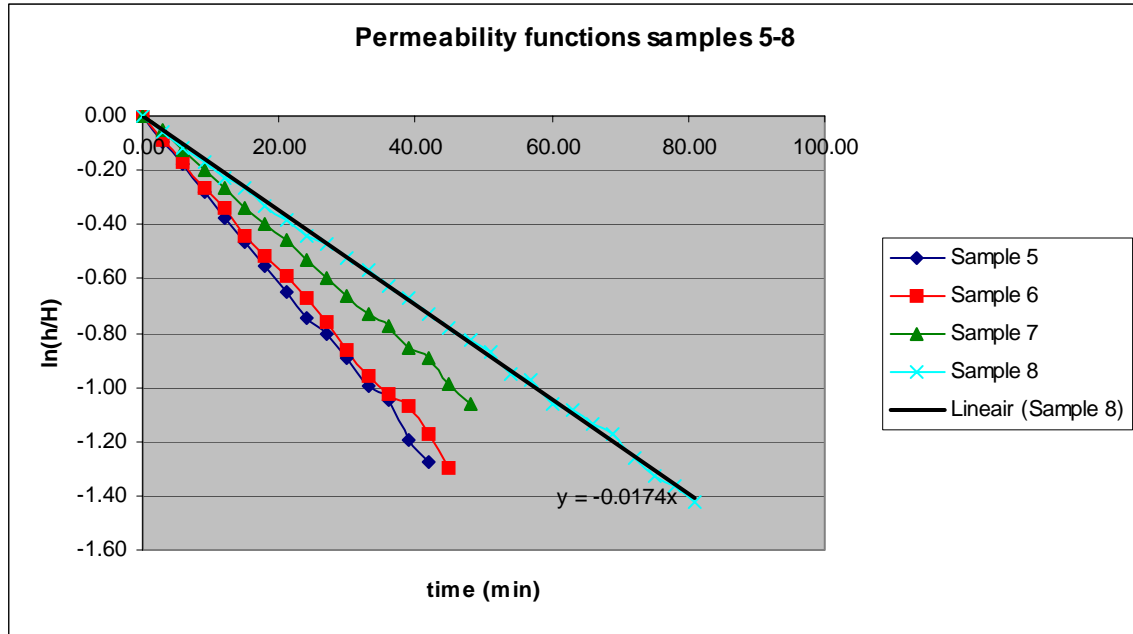

Figure 32: Model of the calculation of the K-values

Research hasn't been done to every soil layer in a cross-section. Until this is done, this model cannot be used. The obtained k-values should be treated as average for the whole cross-section. The experiments from which the permeability functions are drawn in Graph 1 are not all the same, nevertheless they are all from the same location and should therefore not differ this much. The reason of the difference can be found in the clogging of the coarse material during the tests. The samples taken from the Kamunyuni dam, plotted in Graph 1 and Graph 2 will not be used for recharge calculation because of the impossibility of recharge in this area, this was realized after the permeability test. Therefore the tests can be used for the determination of the longitudinal flow in the riverbed.



Graph 1: Permeability functions from silt samples 1-3, from 60 m upstream of the Kamunyuni dam in the middle of the bed



Graph 2: Permeability functions from silt samples 5-8, from 60 m upstream of the Kamunyuni dam in the middle of the bed

The k-values taken from upstream of the Kamunyuni dam are shown in Table 3, the standard deviation is relatively high, which means that the calculated average of the k-values is not that reliable.

sample	k-value	
1	0.00000414	
2	0.00000086	
3	0.00011520	
4	unreliable	
5	0.00022348	
6	0.00019810	
7	0.00021582	
8	0.00011310	
9	unreliable	
Average	Median	Standard deviation
1.2439×10^{-4}	1.520×10^{-4}	9.47×10^{-5}

Table 3: k-values from the silt samples 1-9 from 60 m upstream of the Kamunyuni dam in the middle of the bed

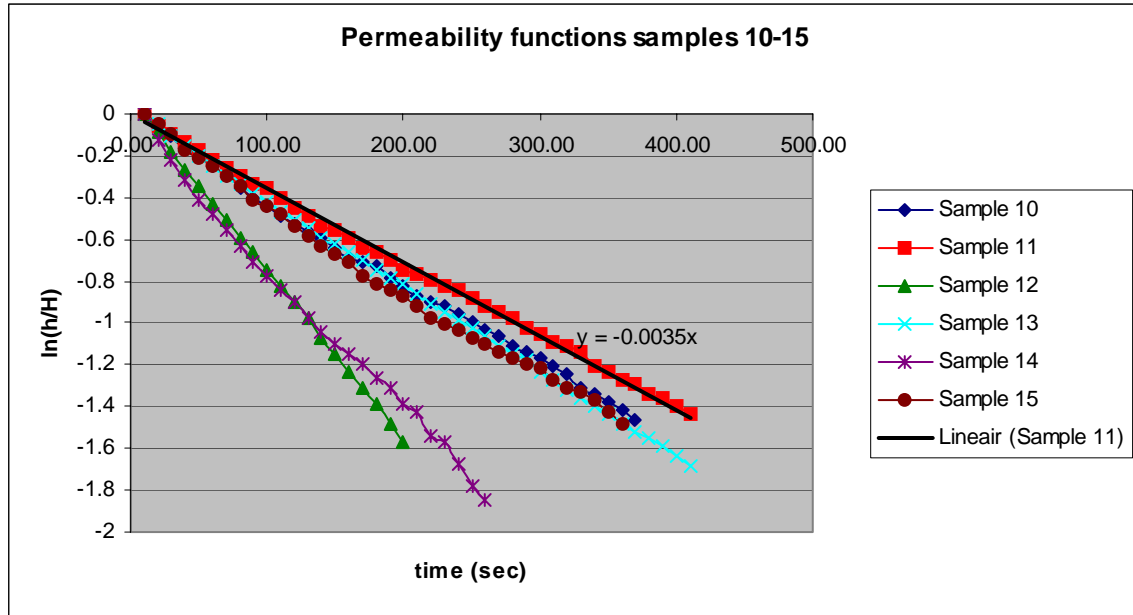

Graph 3: Permeability functions sand samples 10-15, from right banks upstream of the Kamunyuni dam

From the right banks upstream of the Kamunyuni dam the samples 10-15 were taken. The permeability functions of these samples are drawn in Graph 3. The calculated k -values and the standard deviation of these values can be found in Table 4. The standard deviation of these values is in comparison to the samples 1-9 much better, but still the samples are not very reliable.

sample	k-value	
10	0.00002720	
11	0.00001680	
12	0.00004408	
13	0.00002173	
14	0.00002414	
15	0.00002184	
Average	Median	Standard deviation
$2.597 \cdot 10^{-5}$	$2.299 \cdot 10^{-5}$	$9.51 \cdot 10^{-6}$

Table 4: k -values from the sand samples 10-15, from right banks upstream of the Kamunyuni dam

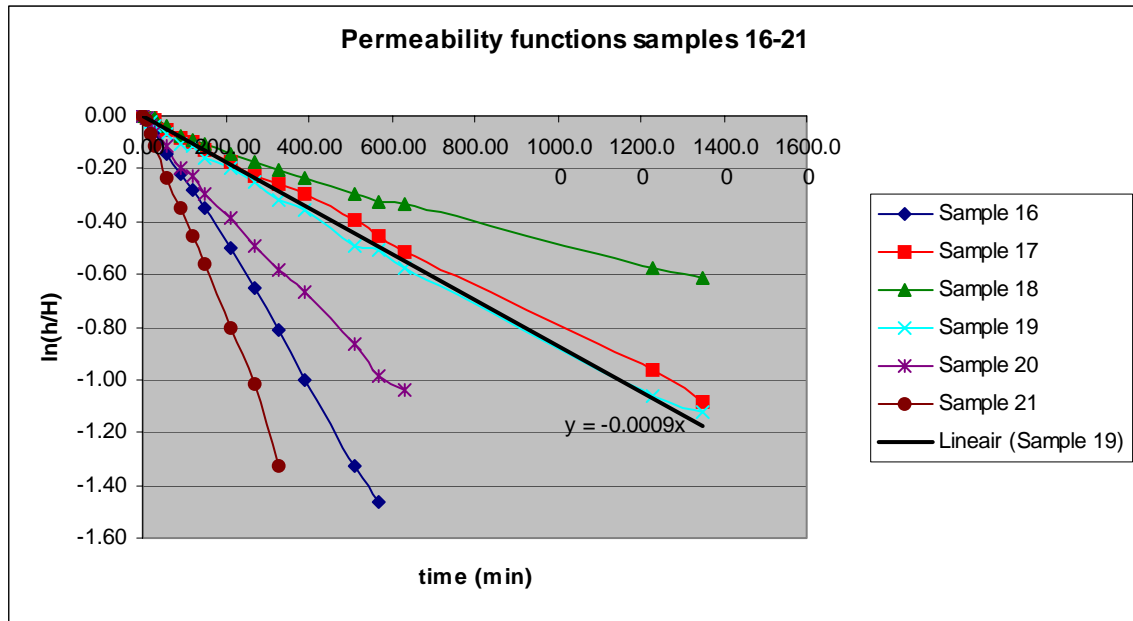

Graph 4: Permeability functions from the silt samples 16-21, from the banks upstream of the Kamunyuni

The samples 16-21 are taken from upstream of the Kamunyuni dam from the right bank. As can be seen in Graph 4, the permeability functions are not alike. The calculated standard deviation of the k -values confirms this finding. This standard deviation which is of the same magnitude as the average k -value, as can be seen in Table 5. Therefore the k -values are not reliable.

sample	k-value	
16	0.00001325	
17	0.00000432	
18	0.00000300	
19	0.00000288	
20	0.00001037	
21	0.00001872	
Average	Median	Standard Deviation
$8.76 \cdot 10^{-6}$	$7.35 \cdot 10^{-6}$	$6.47 \cdot 10^{-6}$

Table 5: k -values from the silt samples 16-21, from the banks upstream of the Kamunyuni

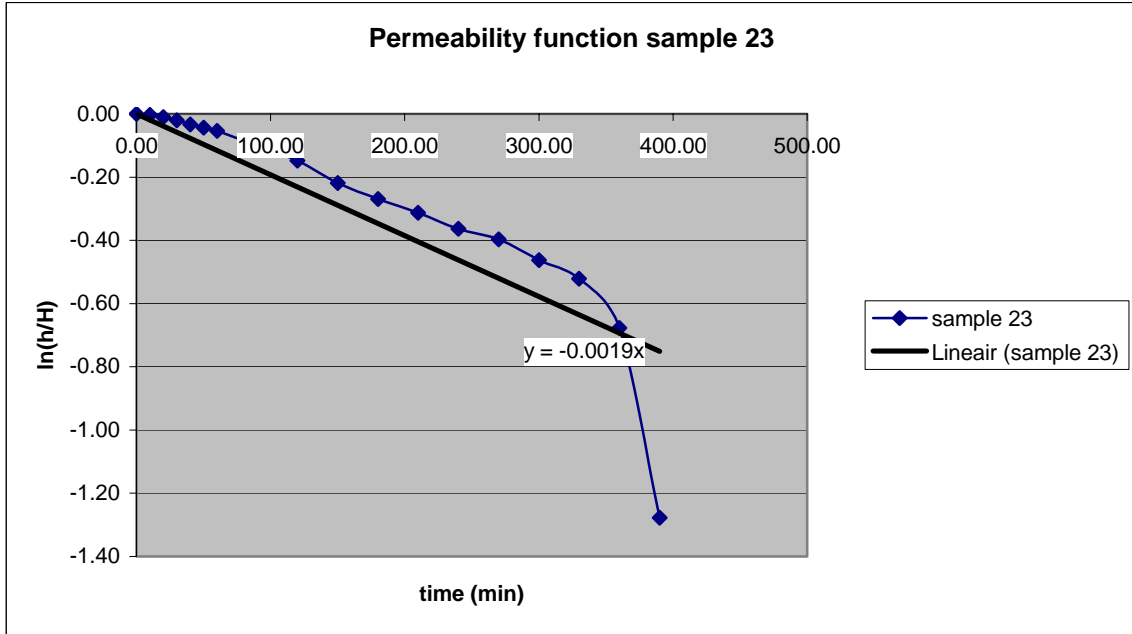

Graph 5: Permeability function of kunkar limestone, sample 23, from shamba at the left side upstream of the proposed site

Samples 22-26 are taken from the shamba from piezometer cross-section 2. Sample 22 failed from the beginning and is therefore not shown in the graph. As can be seen in Graph 5, with sample 23, there is a sudden drop of the water level after some time. Piping caused this. It proves that kunkar limestone is sensitive to piping. Care should be taken when large formations of this soil are encountered around a dam site. The proposed dam site was surrounded by little kunkar limestone. Therefore the site is considered safe.

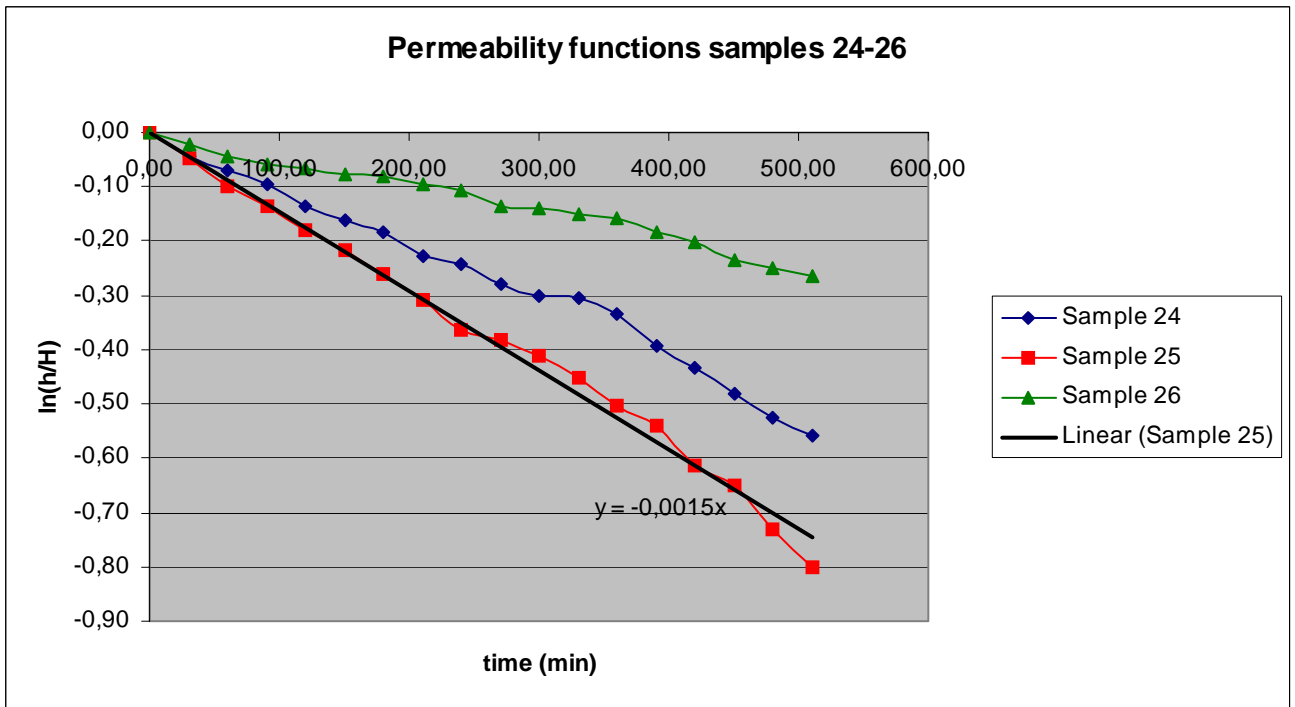

Graph 6: Permeability functions of silt samples 24-26, from the shamba on the left side upstream of the proposed site

sample	k-value	
22	unreliable	
23	0.00001045	
24	0.00000590	
25	0.00000945	
26	0.00000310	
Average	Median	Standard Deviation
$7.23 \cdot 10^{-6}$	$7.68 \cdot 10^{-6}$	$3.37 \cdot 10^{-6}$

Table 6: k-values from the silt samples 22 -26 from the shamba on the left side upstream of the proposed site

In Table 6 the k-values of the samples 22-26 are shown. From the k-values, the average, the median and the standard deviation are calculated. As can be seen in Table 6, the standard deviation is approximately half the value of the average. This means that the k-values are not that reliable.

Porosity

The porosity tests were done on sand samples, coming from upstream of Kamunyuni dam and silt samples from upstream of the proposed dam site. Both sand and silt have a porosity (n) of approximately 30% according to the tests. It seems to be a too high value for silt. Again, a non-compact sample was used. This might cause a higher porosity value than is the case in the aquifer.

Because of the uncertainty about the soil characteristics obtained, computations on behavior of groundwater might be inaccurate.

5.2.2 Piezometers

General

The dam site investigation concluded that the proposed site is the best site. Therefore a network of piezometers was installed around this site. During research period, 3 cross-sections (c-s) were installed to fulfill the objective that groundwater levels should be measurable on upstream and downstream side of the dam before as well as after construction has taken place. The experimental piezometers were tested and are reliable. The heights of the piezometers were all measured in reference to a point as seen in the schematic drawings (Figure 34, Figure 36 and Figure 38). The rims of the tubes were all measured in reference to reference point 4.

C-s 1 is located approximately 150 m. from the dam site, c-s 2 about 50 m. The third c-s is set up downstream from the dam (approximately 30 m). Figure 33 shows the results including the morphology of the river section over approximately 250 m.

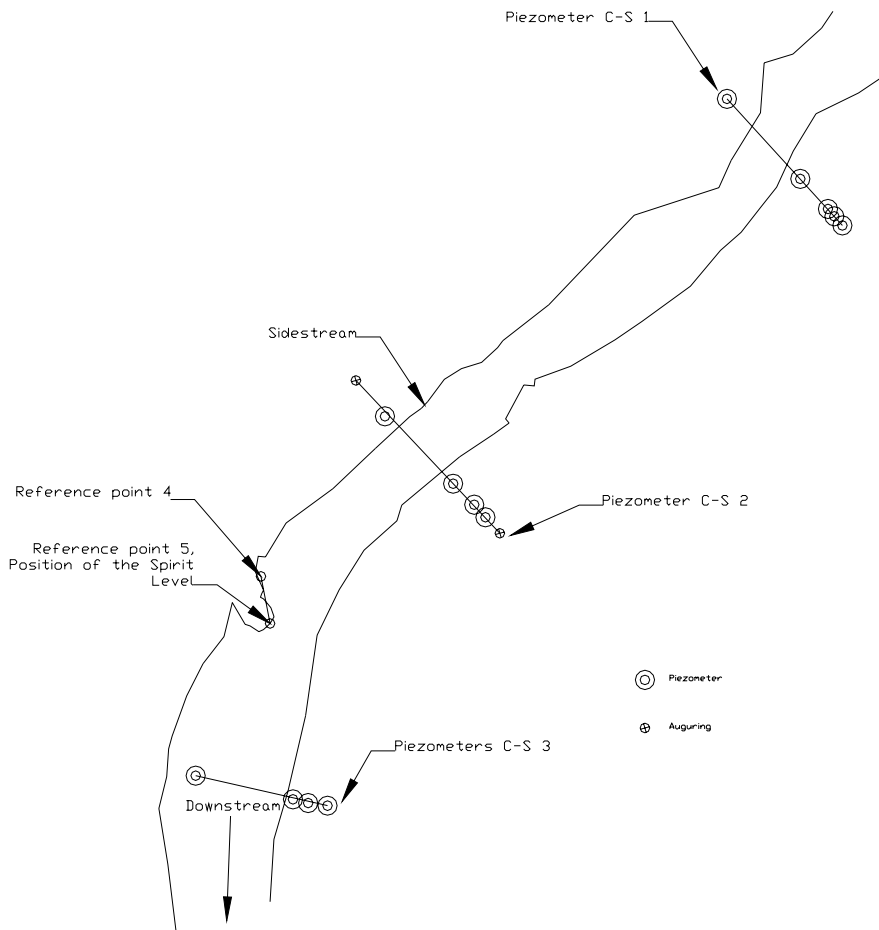

Figure 33: Proposed site with positions of the different Piezometer Cross-sections

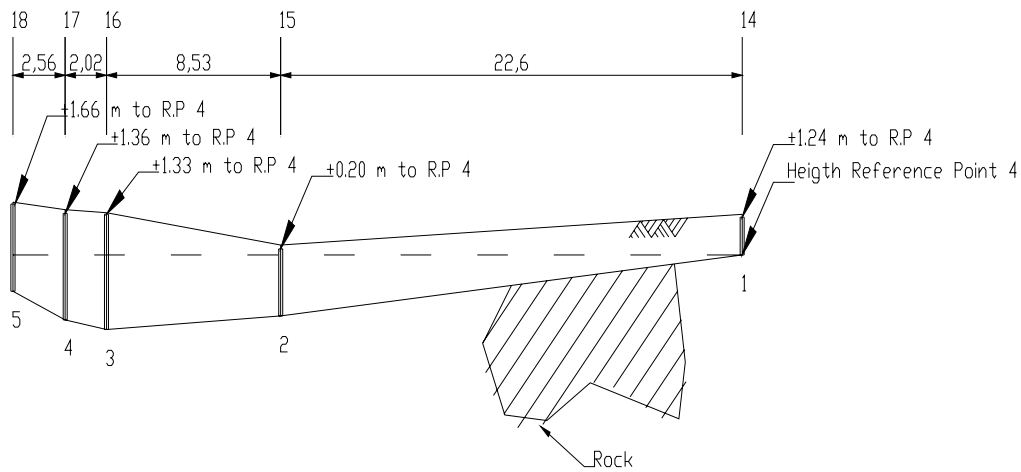

Figure 34: position of the different piezometers in piezometer Cross-section 1

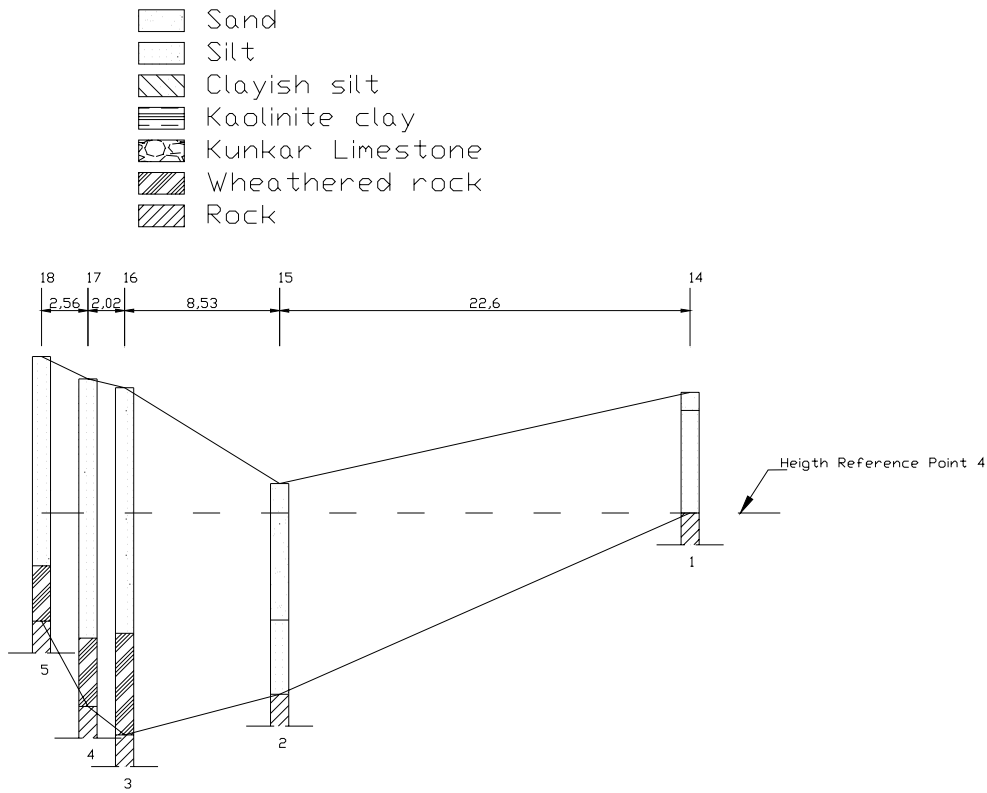

Figure 35: Ground profile of piezometer Cross-section 1

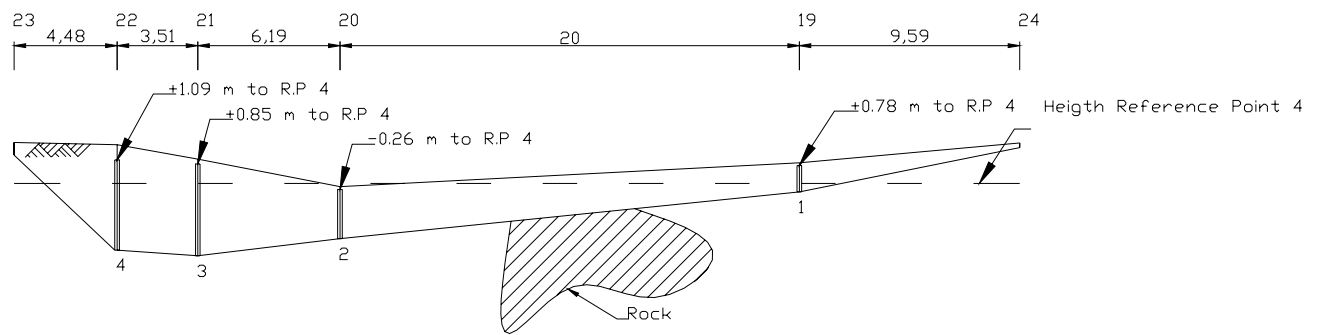

Figure 36: Positions of the different piezometers in piezometer Cross-section 2

Piezometer cross-section 1 and 2:

The expectation is that the influence of the dam will reach much further than 150 m, depending on the height of the dam. This expectation is based on experience of SASOL. Therefore, the c-s is close enough to the dam site. Because of the attractive soil characteristics of the left bank, most of the efforts in placing piezometers were focused on this side. The left bank is shallow enough to get the piezometers on a satisfying depth (> 2.5 m below riverbed). The piezometers were placed on locations where no paths or thick bushes were present. Tube 2 in c-s 1 in the riverbed can be checked with the nearby scoop hole as reference as long as there is water inside this resource. Tube 5 was placed as far in the banks as possible approximately 10 m from the riverbed as can be seen in Figure 35.

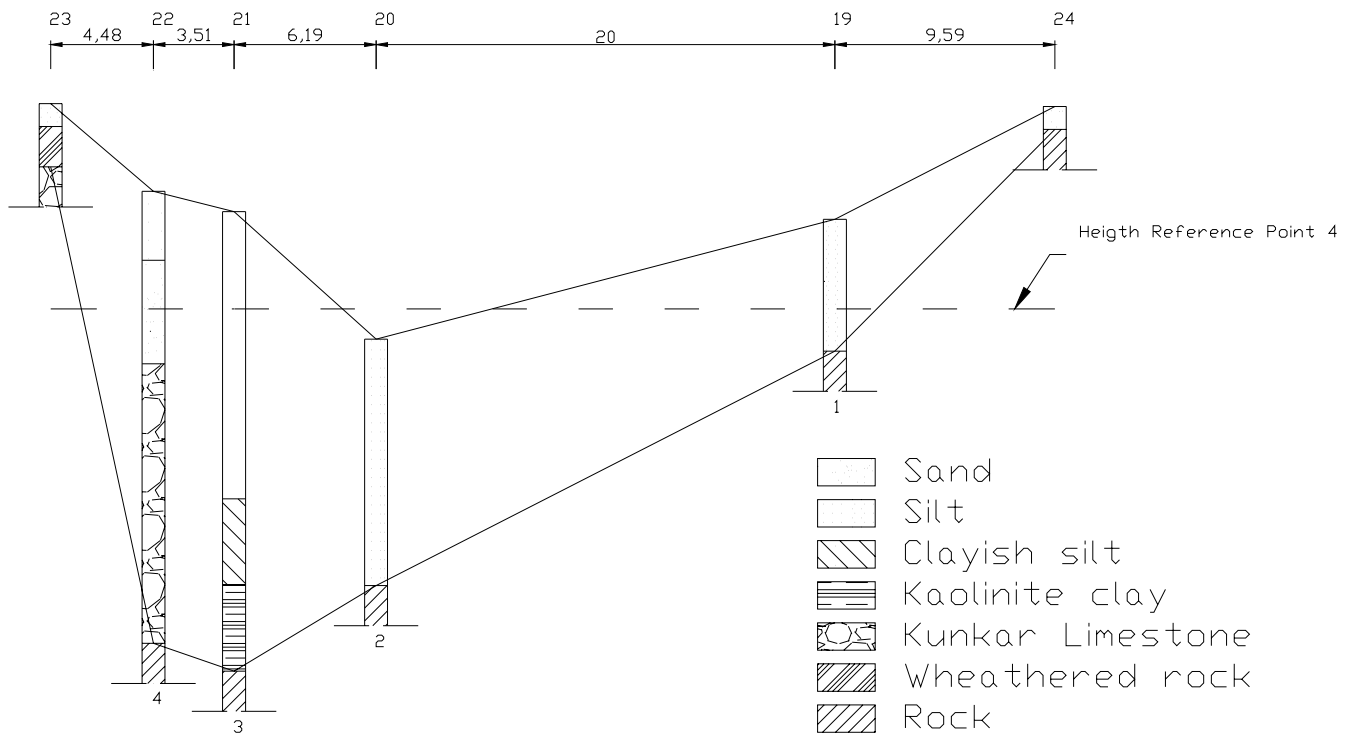

Figure 37: Ground profile of piezometer Cross-section 2

As Figure 35 and Figure 37 show, the rock formation is raising too high to place useful piezometers further bank inwards. Permission to place piezometers in the shamba was granted by the farmer that owns the field.

Piezometer cross-section 3:

This c-s is close behind the dam location, so the dam's influences will be well noticeable here. The left bank is similar to c-s 1 and 2. The right bank is very steep and consists of slightly weathered rock where auguring is impossible. Therefore, the piezometer on the outer right of the c-s was placed in the riverbed instead of in the banks. The riverbed offers little protection against damaging influences like cattle or high velocity water streams that might erode the protecting top layer of sand above the rim of the tube. Therefore it is inadvisable to do this if it is not absolutely necessary. For detailed characteristics of piezometer cross-section 3 (distances between augur holes and height of the piezometers) reference is made to reference point 4, Figure 38.

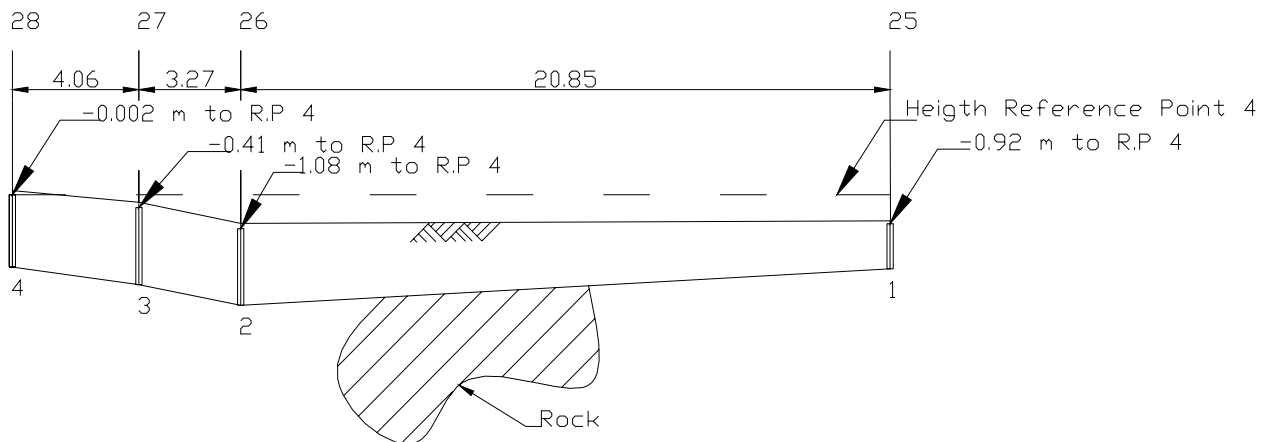

Figure 38: Positions of the different piezometers in Piezometer cross-section 3

Cross-section functions

C-s's 1 and 2 can be used separately to compute infiltration of water in a certain time from the river into the banks in these c-s's (see §3.1.3). The heads in the c-s's of piezometers can also be monitored. In due time, the water table over the c-s should be practically horizontal. This will prove simply by long-term observation that bank infiltration is actually occurring. How far the influence of the bank infiltration will reach depends on the wideness of the banks. In the case of wide banks it will take longer before the lateral water table gradient reaches almost zero. It might cost several rainy seasons before this happens. The total recharge volume will be larger than is the case with narrow banks.

The problem of the researched bank is that the rock layer is very near the riverbed. Because of fractures and fissures in the rock layers, the bank infiltration might have a much larger infiltration length than the placed piezometers cover for. This is a clear limitation of this part of the measuring system.

A longitudinal section of piezometers to a considerable distance upstream (several 100 meters) would make a study on the reservoir volume possible. When the dam is silted up, the reservoir volume will have a certain gradient in the sand, because of the resistance of sand. The longitudinal c-s can measure how far upstream the influence of the dam is still noticeable in this sand bed. Because the process of silting up takes several years, it will take a long time before the final amount of storage by the reservoir is reached. The change in reservoir volume over time because of silting up can be monitored using the longitudinal section. For reservoir volume computation, reference is made to §3.1.4.

A remark should be made about the capillary rise in water. Adhesive forces between soil and water (amount of force is dependent on the size of soil particles) create a non-saturated zone above head-level. The height of the unsaturated zone can be determined through vertical electrical sounding as well in the riverbed as in the banks. This unsaturated zone also stores water. This water is however not available for use.

The estimation of the total stored volume of water by the dam is:

$$V_{total} = V_{reservoir} + V_{recharge} + V_{unsaturated} \quad \text{Equation 19}$$

C-s 3 can compare water levels with c-s 2, thus simply proving that the dam works. When piezometers are placed parallel to the riverbed around the dam in the banks from c-s 2 to 3, the amount of seepage can be monitored.

At the time of study, the latter and the longitudinal section were not installed yet.

5.2.3 Collecting data

At the time of research it was possible to obtain the data from the piezometer network. Several measurements have been done to test the c-s's.

Cross-section	Tube nr.	Height tube to R.P. 4	Measured depth (m), (11-6)	Depth water to R.P. 4	Measured depth (m), (13-6)	Depth water to R.P. 4
1	1	1.24	-	-	-	-
1	2	0.20	2.02	1.82	2.03	1.83
1	3	1.33	Not available	-	3.09	1.76
1	4	1.36	3.07	1.71	3.11	1.75
1	5	1.66	-	-	-	-
2	1	0.78	-	-	-	-
2	2	-0.26	2.06	2.32	2.05	2.31
2	3	0.85	3.57	2.71	3.56	2.71
2	4	1.09	Not available	-	3.61	2.52
3	1	-0.92	-	-	-	-
3	2	-1.08	-	-	-	-
3	3	-0.41	-	-	-	-
3	4	-0.002	-	-	-	-

Table 7: Collected data on ground water levels in the different cross-sections

In Table 7 the groundwater levels measured on the 11th and 13th of June are shown. From these measurements no conclusions can be drawn yet because there have only been two measurements, the measurements are only taken to get an idea of the situation and to start with the measurement program.

However, the readings should be done in absence of project students. At the time of study there were not yet people selected who are willing to measure regularly in the future. Persons should be selected that have benefit in measuring groundwater levels. In this way they will have dedication to the job thus doing it properly. The farmer who owns the shamba might be a good person, however this person was not present during study. An employee of SASOL working in the area can also do these readings.

Future project groups should think of a way to make data collecting easy for local people who are not familiar with hydrologic knowledge. The tubes can, for example, be colored: every tube in a c-s a different color. The reader can fill in the measured heights above the rim in a form at the appropriate color. Calculation of heads can be done in SASOL office using a spreadsheet.

5.2.4 Conclusions and recommendations

Conclusions

- The permeability tests can be considered not very reliable.
- The porosity test on silt resulted in 30% which is too high for silt, the sand on the other hand was with 30% more accurate.
- Kunkar limestone can be unreliable in the permeability test due to the fact that part of the soil dissolves which causes piping. Care should be taken when kunkar limestone is found in the banks surrounding a dam as piping might occur around the construction.
- The piezometers constructed from PVC tubes are found suitable for measuring ground water tables.
- Bank recharge can be monitored using the three piezometer cross-sections.

- Piezometers could not be placed further than 10 meters into the banks because of the presence of rock layers. This does not mean that the infiltration length is directly influenced by these rocks, cracks and fissures can cause a much larger infiltration length.

Recommendations

- More tests should be done on permeability to get a better idea of the soil parameters.
- Care should be taken with materials used for the permeability tests, the course material should not clog.
- More research should be done on soil characteristics, if possible other experiments should be used.
- A longitudinal section of piezometers is needed for determining the influence distance upstream of the dam. This information can be used for estimation of the reservoir volume.
- Ways to read the piezometers should be developed.

5.3 Water balance

5.3.1 General

The water balance is considered to be one of the most important aspects in the scientific proof of the working of sand-storage dams. The water balance is the key to determine whether or not the downstream availability of water decreases when building a sand-storage dam.

The water balance is in the simplest form:

$$Inflow(t) - Outflow(t) = \frac{\Delta Storage}{\Delta t} \quad \text{Equation 20}$$

In the field survey the size of the catchment area is determined. The water balance will be applied in this area. Different parts of the water balance in the hydrological cycle are shown in Figure 39.

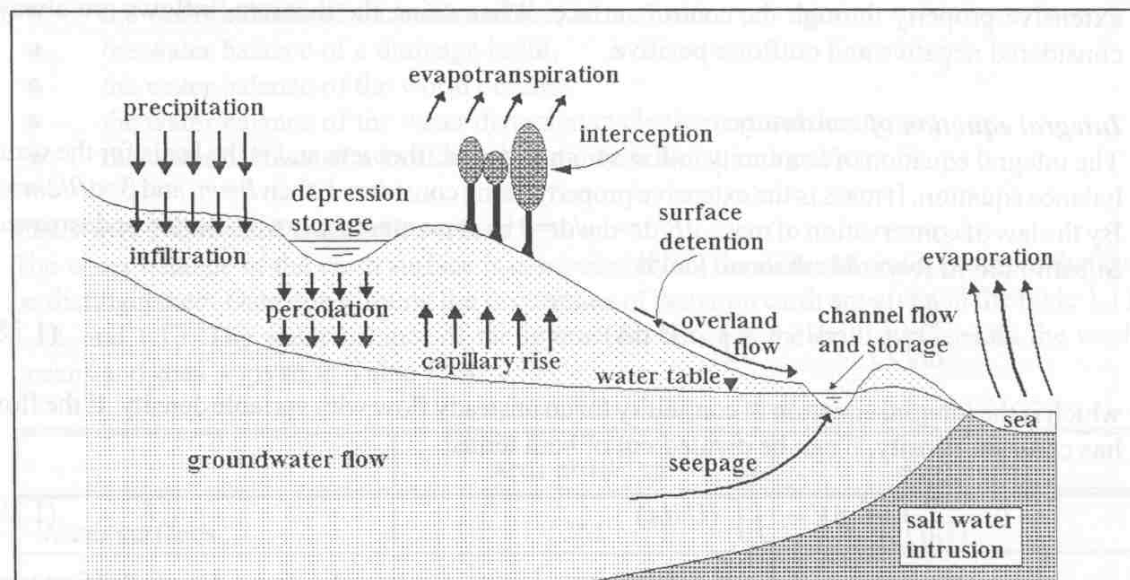

Figure 39: The hydrological cycle

Inflow:

The inflow into the catchment is determined by the inflow over the Kamunyuni dam and the precipitation in the area.

Outflow:

The outflow out of the catchment is determined by the discharge over the border of the system: the proposed site, and the evapotranspiration.

Storage:

The storage is the water that remains in the whole of the catchment area.

5.3.2 Precipitation

During study a start has been made with setting up a rain gauge network: one rain gauge was placed in the area on the topographic divide of the catchment. Especially because Kitui is an ITCZ area, more rain gauges should be installed in the catchment (see §3.2.1)

The rain gauge is placed in an open spot on the compound of Kisayani primary school. The top of the rain gauge is about 40 centimeters above surface level. A fence has been placed around the gauge to prevent disturbance of the outcomes for example by animals. The area of the catchment is hilly and there are many trees in the neighborhood (the nearest tree is on about 20 meters distance from the rain gauge, which is actually less than the criteria demand). Therefore, there are not many places that fit the criteria totally. The compound of the school seemed to be the best place considering all the criteria.

For placing the rain gauge, contact has been made with the teachers of the primary school. Because the cooperation of the school in the further project can be of importance, the science teacher was consulted about setting up a science club, which gave a positive reaction. This science club will read out the rain gauge and can be of help in future simple readings, for example for an evaporation study (wind velocities, temperature and humidity) or measurements of heads in piezometers. The pupils and teachers were given an explanation about rain gauging and the importance of it before installing of the rain gauge took place. A calculator and forms until December 31st have been supplied (example: Appendix VI: Rain gauge form). The filled forms should be handed over to SASOL, for example when the teachers collect their salary in Kitui. No arrangements for this were made yet during study.

At the time of study, further appropriate materials for a science club were not available. Efforts have to be made to provide the school with some science materials.

5.3.3 Discharge

Due to heavy rainfall, discharge can occur over Kamunyuni dam and over the downstream border of the catchment: the proposed site. From observation can be concluded that it is possible to place rulers or staff gauges on sand dams, especially while they are under construction. The device can be placed in the concrete. The dams can be used as measuring device in this way (see §4.2.2 Discharge measurements)

Despite the simplicity of this measurement, there are many practical problems involved. First of all, the time to obtain data (during a flood) is mostly the worst time to measure. It rains fiercely, it happens mostly at night, infrastructure is mostly in bad shape (including phone lines) and there might be many practical problems (car broke down, the one to measure is on a holiday etc.) These factors make doing measurements less attractive. The one who measures should have a certain benefit in it that will drive him/her to do it, even when the circumstances are really bad. The best thing is, to select someone who lives nearby the site and to provide him/her with rain protecting clothes and boots. The second practical problem is that when an extreme flood occurs, the staff gauge might be hard to read because of bad sight or turbulent flow or the site might be inaccessible. During study, no floods occurred so there is no certainty about the

behavior of the river during discharge. In this case other estimating methods should be used to obtain discharge information. Especially during floods, the slope area method might be useful, at least to determine the maximum discharge.

Before a dam is present, the discharge over the downstream border of the catchment, the proposed site, can be determined with dilution gauging or with slope area method, for obtaining the maximum discharge these methods are described in §3.2.2. Because of the rock in the riverbed there will be turbulent flow when there is a significant discharge.

The slope area method can be used directly downstream from the proposed site. A suitable reach is present of at least 150 meters long. The riverbed consists of a straight reach with sand as a top layer. The right bank consists of rock and the left bank of trees. On both sides are enough possibilities to mark flood marks with paint.

5.3.4 Evapotranspiration

To estimate the amount of water leaving a catchment by evaporation and transpiration a study on vegetation and meteorological parameters is needed in the area of interest. A computer model can be created in for example CROPWAT. The following parameters are needed:

- Min. and max. temperature (°C)
- ET_0 and ET-crop values of crops and vegetation present (mm/day)
- Humidity (percentage)
- Sunshine (hr)
- Wind speed (km/day)

Evaporation numbers were not yet known during time of study. However the existence of the science club of Kisayani primary school opened the possibility to initiate a study on meteorological and vegetation parameters (temperature, humidity, amount of sunshine, wind speed and ET-crop and ET_0) and obtain daily readings on the wanted parameters. The science club can benefit by obtaining knowledge on these meteorological phenomenon. Explanation, materials (thermometer, hygrometer, anemometer, bucket) and forms with calculation formulas if necessary are needed to mobilize the science club in gathering this data.

5.3.5 Storage

Note: By storage is meant all the water that retains in the catchment area, not only the water conserved by the dam. The construction of a dam will merely increase the storage.

Theoretically, the order of magnitude of Δ Storage in the catchment area can be obtained (see §3.2.4); the water balance of this catchment, integrated over the account period Δt is given below:

$$\Delta Storage = \int_{t=0}^{t=\Delta t} (Q_{Kamunyuni} - Q_{out} + (P - E)A) dt \quad \text{Equation 21}$$

Δ Storage can be computed over different account periods, which will prove that over a longer term, the amount of storage is negligible in comparison to the in- and outflow.

Evaporation numbers and discharge numbers over both the dam sites are not yet measurable. Until this is done, computation of the water balance is not yet possible. Future studies are needed to obtain the missing parts in the water balance.

5.3.6 Conclusions and recommendations

Conclusions

- Discharge over a dam can be easily measured using simple equipment like a staff gauge.
- Local institutions like schools are willingly to cooperate in the project.

Recommendations

- More rain gauges are needed and should be placed in the catchment area.
- Measuring structures are needed at the dam locations. For example staff gauges.
- The loss of water due to evaporation should be researched.
- Research should be done on the runoff coefficient to get insight in the flows and to be able to determine the storage capacity of the area.
- Research should be done to the order of magnitude of the storage in front of a dam in comparison to the discharge over the dam.

6 Conclusions and recommendations

6.1 Conclusions

Field survey

- The proposed site is the better alternative for building a sand-storage dam.
- Dam site allocation is better with a good field survey.
- Information about the width of the cross-sections is necessary to determine the construction efforts. This width can also be used in calculating the discharge using the slope area method.
- The gradient of the river is one of the most important factors in determining the reservoir volume.
- Presence of fresh rock makes foundation easy and shortens the construction period.
- Auguring is an easy method to determine the depth of the rock layers.
- Pre-design is necessary to determine the depth of the foundation, the construction time and therefore the cost efficiency.
- Groundwater varies in the riverbed, variation in vegetation indicate this.
- Rock formations across the river can behave as natural barriers. They can either be used as dam site because of the easy foundation or as an element in a series of dams.

Groundwater

- The permeability tests can be considered not very reliable.
- The porosity test on silt resulted in 30% which is too high for silt, the sand on the other hand was with 30% more accurate.
- Kunkar limestone can be unreliable in the permeability test due to the fact that part of the soil dissolves which causes piping. Care should be taken when kunkar limestone is found in the banks surrounding a dam as piping might occur around the construction.
- The piezometers constructed from PVC tubes are found suitable for measuring ground water tables.
- Bank recharge can be monitored using the three piezometer cross-sections.
- Piezometers could not be placed further than 10 meters into the banks because of the presence of rock layers. This does not mean that the infiltration length is directly influenced by these rocks, cracks and fissures can cause a much larger infiltration length.

Water balance

- Discharge over a dam can be easily measured using simple equipment like a staff gauge.
- Local institutions like schools are willingly to cooperate in the project. They can execute part of the measurements.
- Due to the short period until the dam will be constructed, no reliable data on discharge can be collected on the site. Therefore the discharge before and after construction of the dam cannot be compared.
- The proof of the working of a sand storage dam is not in the comparison between the discharge before and after construction of the dam but in the comparison between the storage in front of the dam and the discharge over the dam.

6.2 Recommendations

Groundwater

- A lot can be done about the sustainability of the gauging system itself. The piezometers are fragile. A concrete casing to protect the rim of the tubes would be the best solution. A better lid, for example one that fits in the former mentioned concrete casing will provide a more permanent protection against sand falling in degradation by bugs or other animals
- For estimation of the reservoir size, a crosscut of piezometers is needed from the proposed dam site to several hundreds of meters upstream.
- Readings should be done when research groups move away from the field. People should be pointed out to do the measurements on a regular basis.
- To monitor the water table difference at Kamunyuni dam, a piezometer downstream is necessary. At the time of study it was not possible to augur beneath groundwater level because the present soil layer on this depth was sand. Therefore the bore holes collapsed and sand just flushed out of the augur. To get the piezometer as deep as possible, it is advisable to place this piezometer in the end of the dry season because water levels are then much lower than at the time of study.
- When the Kamunyuni reservoir is silted up, the water level is not visible anymore. A piezometer upstream from the dam can make reading of water level, which is now actually groundwater level, again possible. This piezometer should thus be installed after silting up has occurred.
- More tests should be done on permeability to get a better idea of the soil parameters.
- Care should be taken with materials used for the permeability tests, the course material should not clog.
- More research should be done on soil characteristics. If possible other experiments should be used.
- A longitudinal section of piezometers is needed for determining the influence distance upstream of the dam. This information can be used for estimation of the reservoir volume.
- Ways to read the piezometers should be developed.

Water balance

- At the time of study, there was one rain gauge present in the area. To provide more reliable information about rainfall, a higher resolution of measurements is needed, especially in an inter-tropical convergence zone area like Kitui, where rainfall can be very local. More rain gauges should be arranged.
- Measuring structures are needed at the dam locations. For example staff gauges.
- Volunteers to read the staff gauges mentioned before at the moment that the dam starts overflowing must be found. It might be difficult to find a reliable reader, because readings should be done when it rains. A non-reliable reader might not want to measure in an uncomfortable situation like during rainfall. Something like a small reward might convince people to do this work properly.
- The loss of water due to evaporation should be researched.
- Until now, no estimations have been made of the amount of evaporating water. To complete the water balance, research should be done on evaporation.
- Research should be done on the runoff coefficient to get insight in the flows and to be able to determine the storage capacity of the area.
- Research should be done to the order of magnitude of the storage in front of a dam in comparison to the discharge over the dam.

6.3 Continuation of the REAL-project

- A database system can make data processing very easy for SASOL and makes using the results much more easily in a later stadium of the REAL project.
- A new study in relation to the REAL-project should be set up that will compare and interpret the data that is collected before and after construction took place and that will quantify the water balance in the area. This is only possible when all the influences of the water balance as mentioned before can be measured.

6.4 Recommendations for SASOL

- Because cost-effectiveness is for SASOL a very important factor in site selection and construction participation (see figure 1) and cement is the far most expensive factor, it is advisable to gain certainty about the depth of the foundation layer. Some auguring on the site can provide this information.
- The relationship with the Water Department and the ministry of agriculture might prove to be useful in getting equipment, especially for rain gauging. Data, provided by this equipment can be of service for both SASOL and the Water Department

List of references

1. prof. dr. ir. F.B.J. Barends (march 2001) - CT3320, Grondwatermechanica, syllabus*
2. ir. R.H. Boekelman, Drs. G. Bolier, ir. M.J. van Dijk, C.C.A. van Genuchten (September 2002) - CT4420, Geohydrologie, collegedictaat*
3. prof. dr. ir. H.H.G. Savenije, ir. W.M.J. Luxemburg, dr. ir. A. v. Mazijk, H. Savenije (January 2003) – CT4440, Hydrological Measurements, lecture notes*
4. prof. dr. ir. H.H.G. Savenije (May 2000) – CT5450, Hydrology of catchments, rivers and deltas, lecture notes*
5. A.S. Burger, W. Malda, H.C. Winsemius (April 2003) – Project proposition traineeship Kenya, Kitui district, Quantifying the water gains of sand dams*
6. Louis Berger International Inc., Wanjohi consulting engineers (December 1982) – Arid and Semi-arid lands development project Kitui district water resources study: part II: pre feasibility
7. Louis Berger International Inc., Wanjohi consulting engineers (December 1982) – Arid and Semi-arid lands development project Kitui district water resources study: Hydrometeorology, draft final report
8. Louis Berger International Inc., Wanjohi consulting engineers (December 1982) – “Arid and Semi-arid lands development project Kitui district water resources study: Appendix: maps
9. SASOL, University of Nairobi (2000) - Environmental Impact Assessment of Kiindu and Kyuusi rivers, results
10. SASOL, University of Nairobi (2001) - Environmental Impact Assessment of Kiindu and Kyuusi rivers, results
11. J. Muinde (February 2003) – Sand storage dams and groundwater recharge, Kiindu river: a case study
12. B.M.O. Amimo, District Water Office Kitui – Geotechnical assessment of river Semea sediments from vertical electrical sounding-data
13. Matt Fletcher, Hugh Finlay, Geoff Crowther et al (April 2000) – Lonely Planet, Kenya, 4th edition
14. Isabelle Young (February 2000) – Lonely Planet, Healthy travelling Africa 1st edition
15. SASOL, Maji Ufanisi (1999) – Where there is no water, a story of community water development and sand dams in Kitui district, Kenya
16. <http://www.westerveld.nu/> (2003)
17. <http://www.fao.org/docrep/X0490E/x0490e07.htm>

* This literature is available on the faculty of Civil Engineering (CT), UT Delft

Abbreviations

C-s	Cross-section
DIDC	District Information and Documentation Centre
GPS	Global Positioning System
ITCZ	Inter Tropical Convergence Zone
NGO	Non-Governmental Organization
I-s	Longitudinal section
REAL	Re-hydrating the Earth in Arid Lands
SASOL foundation	Sahelion Solutions foundation
CICAT	Centre for International Cooperation and Appropriate Technology)
UT Delft	University of Technology Delft

Terminology

Account period	The period over which a water balance is established
Augur	Device, used to make small boreholes, also called augur holes
Augur c-s	Cross-section where auguring has taken place for execution of soil research
Bank infiltration	phenomenon that occurs when the water table in a reservoir is higher then the groundwater table in the neighboring banks: Water flows bank inwards
Baraza	Community meeting
Base flow	Slow sub-surface flow in a hydrograph
Bilharzia	Disease caused by parasitic worms that live the first part of their lives in freshwater snails. One can be infected by swimming or bathing in risky water
Bypass	Occurring of piping in a bank when water is blocked in its original stream
Capillary rise	Rise of groundwater above head level in an unsaturated zone, caused by adhesive forces of the soil
Cash crops	Crops grown for selling
Catchment	Influence area of a river (section). Theoretically, all the effective precipitation in this area will flow to this river (section)
Conductivity meter	Device that can measure conductivity. It can be used for dilution gauging
Cost-effectiveness	The relation between quantification of costs and results
Cross-section	Section perpendicular on a river coarse
Darcy's law	Formula used to calculate non-turbulent groundwater flow
Dilution gauging	Method to obtain discharge information by measuring conductivities a certain distance downstream from a salt injection point
Discharge	Flow of water over a barrier or through a river section
Downstream	Direction in river where water flows to
Effective rainfall	Volume of rainfall in a certain time that stays in the catchment
Erosion	Deterioration of soil layers by outside influences

	like wind and water
Evapotranspiration	Evaporation of water from earth or water surface and transpiration of water by plants
Fall	Lowering of a level
Field survey	Study to obtain information about the area of interest
Gauging program	System that enables gathering data for a scientific/hydrological study
Gradient	The angle of the fall of (water)tables
Hydraulic head	Reference height + pressure head above it
Hydrograph	Graph that shows the time distribution runoff, caused by a shower
Infiltration length	Distance in banks that infiltration water reaches in a certain time
Inflow	Amount of water that enters a catchment in a certain time-interval
Inter Tropical Convergence Zone	Tropical region where the air masses originating from the tropics of Cancer and Capricorn converge and lift thus creating the occurrence of wet and dry seasons.
Inverse distance method	Interpolation method for estimating values in non-observed points, using the inverse of the distance as a weight
Kikamba	Local language spoken by the Akamba tribe (Eastern Kenya)
Longitudinal section	Section parallel with a river coarse
Malaria	Disease caused by a parasite (plasmodium), carried by a type of mosquito present in most (sub)tropical areas below 2000 m. It causes vomiting, diarrhoea and many other complications
Morphology	Meandering of the river through its environment
Moving method	Method to map large areas with a spirit level
Natural barrier	Barrier consisting of fresh rock that blocks the water flow in a river coarse
Outflow	Amount of water that exits a catchment in a certain time-interval
Permeability	Soil characteristic that indicates how easy water flows through soil
Piezometer	Device to measure hydraulic heads
Piezometer c-s	Cross-section where auguring has taken place for both soil research and placing piezometers
Piping	Phenomenon that involves flushing out of soil when groundwater flows become too large
Plop-device	Device for measuring water levels in a piezometer
Porosity	Available percentage of pores in soil
Rain gauge	Device for measuring precipitation, in this study consisting of a funnel and a storage cup
Recharge volume	Volume of water stored in the banks behind a sand dam next to the reservoir
Reference point	Point where measurements can be related to
Reservoir volume	Volume of water stored directly behind a sand dam in the sand bed

Roof catchment	Way of conservation of water by collecting it from a roof. Mostly applied with large surfaces like hospitals or schools.
Rotation method	Method that enables detailed mapping of small areas from one point with a spirit level
Runoff coefficient	The portion of rainfall in a catchment that comes to runoff in due time
Salinity	Concentration of salt in water
Sand dam	Dam that creates a reservoir in a sand bed that sedimentates upstream from the dam
Scoop hole	Hole in or close to riverbed used as a water resource
Seepage	Amount of lost water by flows around a barrier
Shallow well	Well, built closely upstream from a dam
Shamba	Agricultural land
Silting up	Gradual filling of a sand dam reservoir by sand
Slope area method	Method based on observation to obtain the maximum discharge of a flooding, after the flooding has occurred
Soil characteristics	Facts that determine the type of soil and how water behaves in it
Spillway	Rim of a dam where discharge of water takes place
Spirit level	Device for measuring distances and elevations in an area
Staff gauge	Staff with a ruler scale of mostly 5 m. length
Subsistence crops	Crops grown for self-sustenance
Surface runoff	Fast surface flow in a hydrograph
Thiessen polygons method	Interpolation method for estimating rainfall numbers by equalizing with neighboring points
Upstream	Direction in river where water comes from
Vertical electrical sounding	Method to obtain information about soil layers and unsaturated water tables
Water balance	Balance for determining the course of water in a Catchment
Water divide	Edges of the influence area of a main or side stream

Appendix I: Used equipment

1 Spirit level and staff gauge

1.1 Moving method

For measuring fall, bends and distances between certain sections and the width of the river, the so-called 'moving method' was used (for direction agreements, see Figure 40).

To measure the fall, the spirit level was placed between two staff gauge locations. This can be seen in Figure 41

The bend made over two sections was determined by the degrees of rotation from a straight line. This was done by subtracting the degree of rotation of the compass on the spirit level from 180° (straight line). Figure 42 visualizes the procedure. Note: the angle around the staff gauge cannot be measured. Therefore, the angle made over the staff gauge when replacing the spirit level was always 180° .

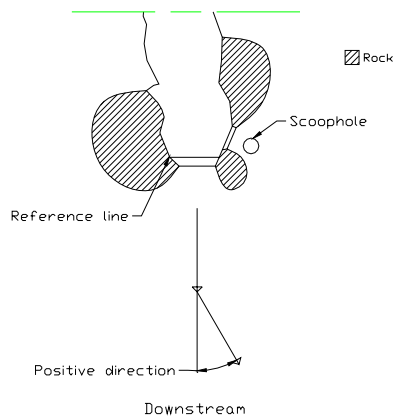

Figure 40: Positive chosen direction and angles, seen from the reference point on Kamunyuni dam

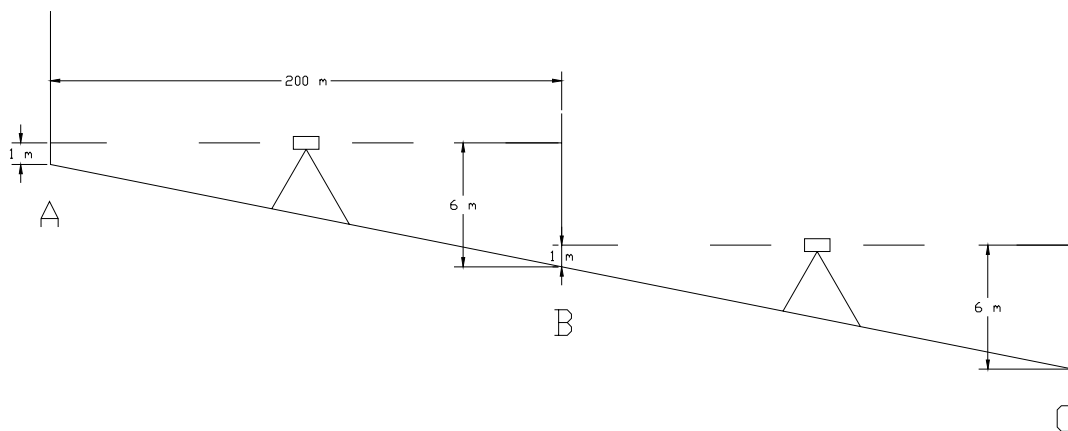

Figure 41: Measuring falls between sections. The fall between the points A and B is five meters over the distance of two hundred meters. This is a fall of 2.5%. This figure also indicates that the fall is measured between two staff gauge locations.

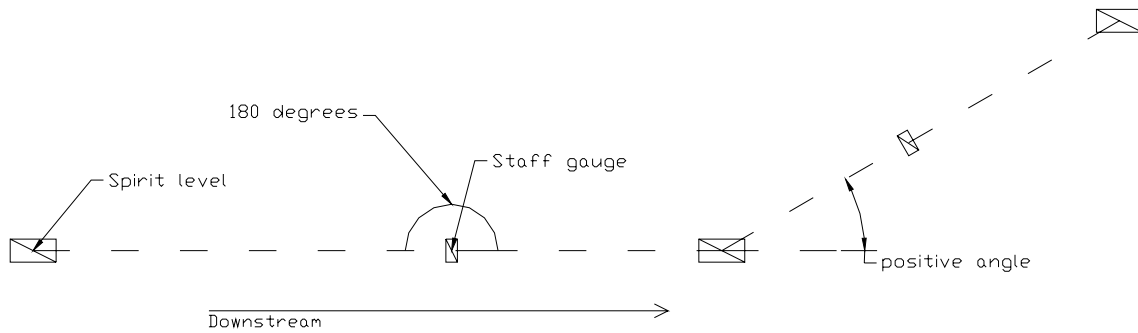
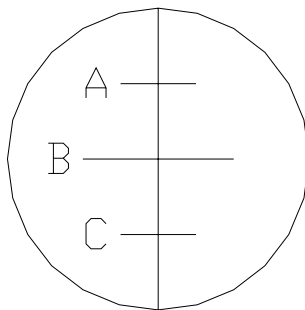

Figure 42: Method of measuring angles, overview from above

Distance between two sections was determined by reading the difference of the two outer lines in the staff and multiplying them with 100 (see Figure 43).



Explanation: The distance was calculated with the following formula:

$$Dist = 100(a - c)$$

The width in a cross-section was measured by placing the spirit level at the lowest point and placing the staff gauge in both banks of the river cross-section and adding the distances read from the binocular. Figure 44 visualizes this.

Figure 43: spirit Level

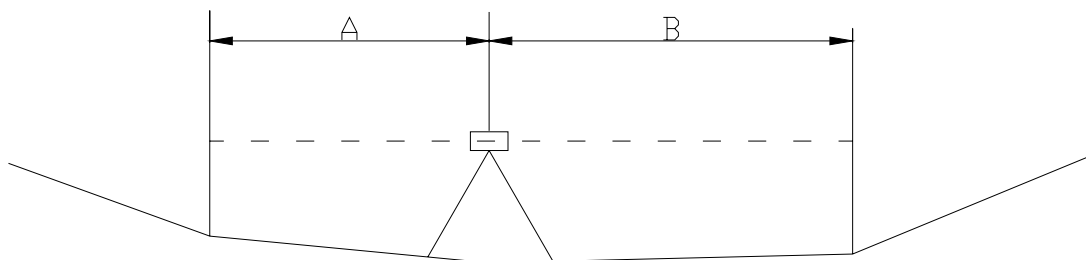

Figure 44: spirit level for the width of the river

1.2 Rotation method

For both dams and cross-sections, the same method was used to map them. The spirit level was placed on a reference point or a point that was known according to a previously used reference point. Again, an easily recognizable spot was chosen. Enough points on the border of the area to be mapped had to be visible at the spot where the spirit level was located. A reference angle was chosen (for example: perpendicular to a dam site). The following procedure was used:

The spirit level was never to be moved in any way during the process of mapping. The staff gauge was placed on a, from the point of view of the spirit level, visible spot on the edge of the area. The angle compared to the reference angle, the difference in height and distance were read and written down. This procedure had to be repeated several times, while the staff gauge moved over the border of the area. The number of points measured determined the resolution of the map. This method is called the 'Rotation method' because the spirit level is only rotated in the process and not moved.

The area was determined by plotting every point from the origin by drawing the measured distance over the measured angle and connecting every spot. Because also elevations along the area's border were measured, the measured spots are marked with this height in the results.

2 Augur

The augur that was used is a manual augur. The augur consists of elements of one meter length, which can be combined by screwing them together. The augur has four of these elements. When all elements including the top and the head are used the total length is 5.20 meters. By turning the augur, using some pressure, a hole can be made. The augur is equipped with two different heads for different soil types. The bigger head is suitable for siltish soils and rough soils like weathered rock and coarse gravel. The smaller head is suitable for clay and other soft materials.

Appendix II: Piezometers

1 Making piezometers

Piezometers were made using PVC-tubes with inner diameters of 2 inches (50.8 mm) and 2.2 inches (55.9 mm) and a thickness of 1 mm. A hot arc saw blade of approximately 1 mm thick was used to perforate the tubes over each meter with cuts of 10 to 15 cm. The bottoms of the tubes were closed using a lid of 2 inch diameter. These were also perforated. They were attached to the bottom using PVC-glue. The cuts were needed to facilitate flow of water into and out of the tubes. The tops of the tubes were closed using lids made from pieces of the same pipes. They were closed on top with the same 2 inch lids used to close the bottom of the piezometers. (see Figure 45)

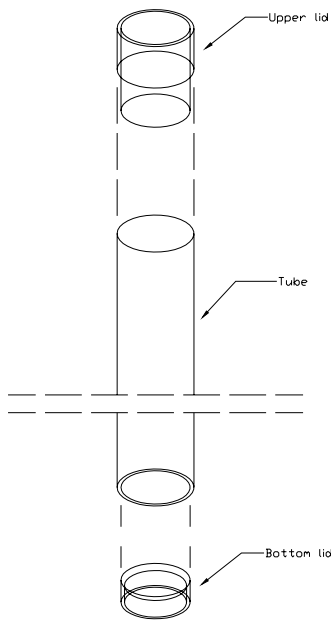

Figure 45: Tube with lid at both sides

2 Plop devices

The plop devices, used to measure the water levels inside the piezometers, were manufactured of a little cup (normally used to store photographic films) attached to fishing wire. The construction needed weight to keep the fishing wire straight, thus making measurements more accurate. Small pieces of fishing lead were used to make the device heavier. To keep the cup horizontal, some lead was attached to the inside of the cup. Figure 46 shows a photograph of the plop device.



Figure 46: Plop device in action

3 Calculation of heads

The heads are calculated with reference to a certain point that is the same for each piezometer placed. The reference level is the height of reference point 4. So the head of the water level can be calculated by using the following formula:

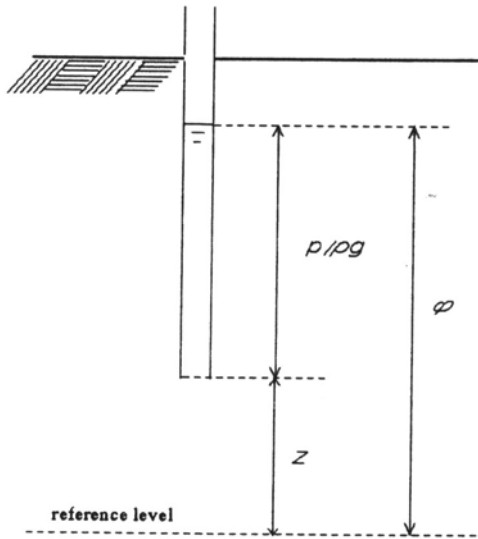

Figure 47: Calculation of the heads

Appendix III: Permeability and Porosity tests

The method of calculating the permeability is based on the formula of Darcy:

$$Q = -k.A.\frac{h-h_0}{L}$$

- Q : discharge
 k : hydraulic permeability
 A : Surface of sample perpendicular on flow-direction
 $h-h_0$: hydraulic head difference over distance L
 L : Height of the soil sample, distance over which the hydraulic head declines
 H : Length of the tube

In this experiment, $h_0=0$ m. The general formula for discharge is:

$$Q = A.\frac{\partial h}{\partial t} \quad \text{Substitute these two:}$$

$$\frac{\partial h}{\partial t} = -k.\frac{h}{L}$$

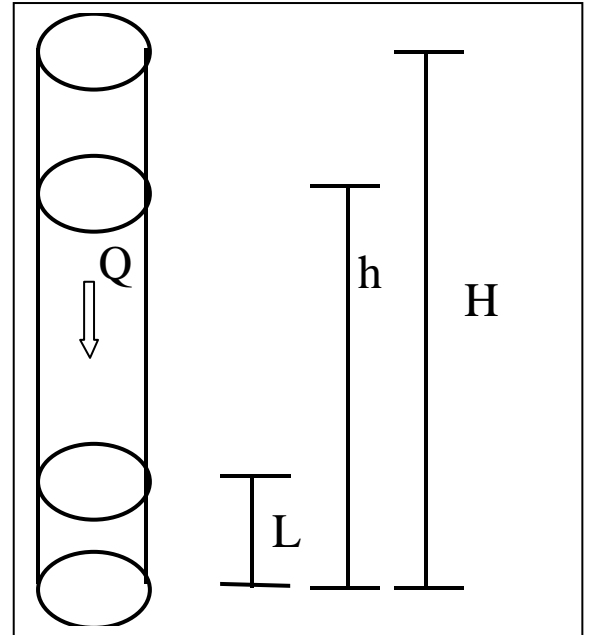

Figure 48: permeability measuring

So therefore:

$$h = H.e^{-k\frac{t}{L}}, \text{ and therefore:}$$

$$k = -\frac{L}{t}\ln\left(\frac{h}{H}\right)$$

By measuring h every couple of minutes or seconds a table of measurements appears. A graph ($t, \ln(h/H)$), shows indeed that the head has a logarithmic form. To make calculation of k possible, this formula can be drawn on logarithmic paper. Linear regression on the graph gives a function of the form:

$$y = a.x + b \quad \text{with}$$

$$y = \ln\left(\frac{h}{H}\right);$$

$$a = -\frac{k}{L},$$

$$x = t$$

By drawing this function the constant a can be determined. With L known the permeability k can be calculated.

Appendix IV: Tables field survey

The data with which the length profile of the river is drawn is in the tables 1, 3 and 5. The tables 2 and 4 are showing the width that is measured. The length profile is measured using sections. A section is the part between the spirit level and the staff gauge. The degree is taken in between of two sections. This is always the place where the spirit level is standing. The fall is the total fall over the two sections. From the position of the staff gauge the GPS coordinates are drawn.

Table 1 is the length profile upstream of the Kamunyuni dam, this is measured starting at the Kamunyuni dam going upstream and is documented from the most upstream part to downstream. This means that the starting point is not recognizable in the field. The start degree in table 3 is the angle between the dam and the river and is 81 degrees.

The width is measured in between of the sections. For the downstream part of the proposed site no width has been measured.

Section nr.	Distance (m)	Degree (°)	Height (m)	Fall (m)	GPS positions of the staff gauge		
					Degrees	Minutes	Direction
1	38.5	60	1.240	-0.780	01°	42.147'	South
2	22.5		2.020		038°	10.793'	East
3	26.4	105.5	1.223	-0.992	01°	42.169'	South
4	27.8		2.215		038°	10.821'	East
5	20.0	-37	0.590	-1.120	01°	42.185'	South
6	36.5		1.710		038°	10.854'	East
7	24.0	21	1.655	-0.635	01°	42.165'	South
8	16.5		2.290		038°	10.861'	East

Table 8: Length profile of the Ngunga River, upstream of the Kamunyuni dam

Section nr.	Height S.L. (m)	Length left (m)	Height left (m)	Fall Left (m)	Length right (m)	Height right (m)	Fall right (m)
1,2	1.285	14	1.285	0.000	0	-	-
3,4	1.497	7.3	1.270	-0.227	4.9	1.320	0.177
5,6	1.560	5	1.572	0.012	2.5	1.440	0.120
7,8	1.575	5.3	1.578	0.003	9.5	1.275	0.300

Table 9: Width of the river, upstream of the Kamunyuni dam

Section nr.	Distance (m)	Degree (°)	Height surface level(m)	Fall surface level(m)	GPS positions of the staff gauge		
					Degrees	Minutes	Direction
	Start degree	81			01°	42,164'	South
					038°	10,894'	East
9	115		0.620		01°	42,120'	South
10	49	44	1.880	-1.260	038°	10,962'	East
11	42		1.300		01°	42,089'	South
12	24	57	1.790	-0.490	038°	10,973'	East
13	29.5		1.255		01°	42,074'	South
14	31	65	1.995	-0.740	038°	10,957'	East
15	28		1.280		01°	42,059'	South
16	29	-82	1.780	-0.500	038°	10,935'	East
17	38		1.155		01°	42,015'	South
18	68	-52	2.130	-0.975	038°	10,964'	East
19	74		0.970		01°	41,980'	South
20	54.5	-29	1.940	-0.970	038°	11,019'	East
21	63		1.105		01°	41,950'	South
22	89	3	2.370	-1.265	038°	11,094'	East
23	36.5		1.300		01°	41,965'	South
24	54	-48	2.100	-0.800	038°	11,139'	East
25	16		1.480		01°	41,961'	South
26	35.5	45	1.930	-0.450	038°	11,165'	East
27	29.5		1.225		01°	41,956'	South
28	87	1	2.250	-1.025	038°	11,224'	East
29	70.5		1.075				
30	6.5	24	1.672	-0.597			
31	9.4		1.535				

Table 10: Length profile of the Ngunga River, downstream of the Kamunyuni dam

Section nr.	Height S.L. (m)	Length left (m)	Height left (m)	Fall Left (m)	Length right (m)	Height right (m)	Fall right (m)
9,10	1.525	9.0	1.480	-0.045	0.0	-	-
11,12	1.598	14.0	1.585	-0.013	5.0	1.540	0.058
13,14	1.616	11.2	1.502	-0.114	2.6	1.568	0.048
15,16	1.518	3.0	1.550	0.032	7.0	1.510	0.008
17,18	1.570	2.0	1.598	0.028	9.5	1.552	0.018
19,20	1.580	3.6	1.500	-0.080	13.3	1.548	0.032
21,22	1.580	8.1	1.625	0.045	6.2	1.660	-0.080
23,24	1.580	2.2	1.595	0.015	11.8	1.408	0.172
25,26	1.535	14.0	1.586	0.051	16.0	1.650	-0.115
27,28	1.560	1.5	1.518	-0.042	12.0	1.500	0.060
29,30	1.595	10.0	1.560	-0.035	6.0	1.572	0.023

Table 11: Width of the river, downstream of the Kamunyuni dam

Section nr.	Distance (m)	Degree (°)	Height surface level (m)	Fall surface level (m)	GPS positions of the staff gauge		
					Degrees	Seconds	Direction
Height S.L.			1.595		01°41.931'	South	
32	37.0	36	1.820	-0.225	038°11.281'	East	
33	32.5	30	1.455		01°41.887'	South	
34	41.5		2.025	-0.570	038°11.306'	East	
35	20.4	4	1.445		01°41.841'	South	
36	63.0		2.030	-0.585	038°11.313'	East	

Table 12: Length profile of the Ngunga River, downstream of the proposed site

augur	depth(m)	soil type	GPS		augur	depth(m)	soil type	GPS	
1	0	fine sand	38°10'853" east		2	0	fine sand	east	
	0.8	coarse sand	01°42'174" south			1	rock	south	
	1	rock							
3	0	fine sand	38°10'861" east		4	0	silt	38°	east
	1.15	water	01°42'172" south			0.4	clay	01°	south
						0.6	rock		
5	0	clayi sand	38°10'869" east		6	0	clayi sand	38°10'874" east	
	1.6	stony sand	01°42'156" south			0.4	stony sand	01°42'162" south	
	1.7	water				0.7	rock		
	1.8	rock							
7	0	silt	38°10'926" east		8	0	silt sand	38°10'924" east	
	0.5	rock	01°42'154" south			0.35	silt	01°42'148" south	
						0.5	not augerable		
9	0	sandy clay	38°10'943" east		10	0	sand with iron	38°10'942" east	
	1.62	water	01°42'138" south			0.2	sand	01°42'143" south	
						1.3	water		

Table 13: Augurings, soil types, upstream of the Kamunyuni dam

Section nr	Distance (m)	distance total(m)	Height surface level (m)	Fall Surface (m)	Surface level (m)	Height water table (m)	Fall water table (m)	water table (m)
					ref. point:		-0.260	dam's crest
1		11.5	0.380		0	0.640	-1.915	-1.055
2	11.5	11.5	1.500			2.555		
3	32.5	79.5	1.500	-0.505	-0.505	2.555	-0.857	-1.912
4	35.5	79.5	2.005			3.412		
5	31	162.5	1.390	-0.610	-1.115	2.797	-0.244	-2.156
6	52	162.5	2.000			3.041		
7	43	237.5	1.304	-0.638	-1.753	2.345	-0.337	-2.493
8	32	237.5	1.942			2.682		
9	16.8	260.7	1.482	-0.309	-2.062	2.222	-0.095	-2.588
10	6.4	260.7	1.791			2.317		
11	17.4	312.6	1.446	-0.574	-2.636	1.972	-0.443	-3.031
12	34.5	312.6	2.020			2.415		
13	18	346.4	1.525	-0.300	-2.936	1.920	-0.323	-3.354
14	15.8	346.4	1.825			2.243		
15	11	371.4	1.662	-0.266	-3.202	2.080	-0.208	-3.562
16	14	371.4	1.928			2.288		
17	19.8	408.0	0.925	-0.417	-3.619	1.285	-0.166	-3.728
18	16.8	408.0	1.342			1.451		
19	12.3	432.9	1.479	-0.275	-3.894	1.588	-0.664	-4.392
20	12.6	432.9	1.754			2.252		
21	21.3	474.7	1.592	-0.258	-4.152	2.090	-0.355	-4.747
22	20.5	474.7	1.850			2.445		
23	23.5	533.7	1.575	-0.370	-4.522	2.170	-0.360	-5.107
24	35.5	533.7	1.945			2.530		
25	26.5	573.5	1.450	-0.270	-4.792	2.035	-0.400	-5.507
26	13.3	573.5	1.720			2.435		
27	21.2	626.2	1.580	-0.390	-5.182	2.295	-0.705	-6.212
28	31.5	626.2	1.970			3.000		
29	33	684.9	1.440	-0.440	-5.622	2.470	-0.423	-6.635
30	25.7	684.9	1.880			2.893		
31	45	758.3	1.165	-0.657	-6.279	2.178	-1.043	-7.678
32	28.4	758.3	1.822			3.221		
33	20.7	791.8	1.596	-0.263	-6.542	2.995	-0.011	-7.689
34	12.8	791.8	1.859			3.006		
35	34.7	860.3	1.310	-0.608	-7.150	2.457	-1.585	-9.274
36	33.8	860.3	1.918			4.042		
37	23.2	910.6	1.428	-0.493	-7.643	3.552	-0.110	-9.384
38	27.1	910.6	1.921			3.662		
39	46	997.6	1.330	-0.695	-8.338	3.071	-0.530	-9.914
40	41	997.6	2.025			3.601		
41	49.1	1070.4	1.216	-0.590	-8.928	2.792	-1.714	-11.628
42	23.7	1070.4	1.806			4.506		

Table 14: Length profile of the Ngunga River with ground water table

The points in Table 15 are gathered using the rotation method. The angle in this table is the angle from the reference line, which is determined by the reference point 2 and 3 see Table 21, with the points measured. The turn to the left is considered to be positive.

Point Nr.	Distance (m)	Angle (°)	Fall (m)
1	5.8	255	2.150
2	14.2	233	2.168
3	23.6	225	2.322
4	55.5	227	2.660
5	70.0	230	2.805
6	77.0	230	2.875
7	79.0	221	2.825
8	72.0	216	2.735
9	67.5	210	2.650
10	59.5	201	2.550
11	47.3	183	2.330
12	42.8	181	2.870
13	39.6	185	2.383
14	38.2	183	2.341
15	40.5	179	2.185
16	30.0	162	2.250
17	35.2	150	2.230
18	33.0	138	2.177
19	31.3	131	2.145
20	24.2	108	2.068
21	19.0	65	1.950
22	21.5	32	1.785
23	68.0	24	1.365
24	42.5	12	1.655
25	21.0	0	1.815
26	17.5	17	1.862
27	16.2	6	1.888
28	7.7	356	1.900
29	2.7	99	2.064
30	3.2	179	2.072
31	4.8	125	2.073
32	13.8	20	1.783
33	10.2	76	1.978
34	9.7	111	2.026
35	12.0	151	2.008
36	7.3	140	2.050

Table 15: Data of the area around natural barrier gathered with the rotation method

Augur Nr	Distance (m)	Height soil (m)	Height water table (m)	Height rock (m)	Distance between rock and surface level (m)	Angle with reference line (°)
1	35.5	-2.170	-	-2.170	0.000	148
2	29.5	-2.145	-	-3.090	0.945	148
3	25.9	-2.122	-	-2.942	0.820	148
4	22.7	-2.062	-	-2.944	0.882	148
5	19.5	-2.014	-	-2.777	0.763	148
6	16.5	-1.945	-	-2.685	0.740	148
7	13.7	-2.027	-	-2.777	0.750	148
8	11.2	-1.965	-	-2.861	0.896	148
9	7.1	-1.993	-	-2.860	0.867	148
10	3.4	-2.062	-	-2.171	0.109	148
11	-6.8	-1.870	-	-2.117	0.247	-32
12	-13.2	-1.676	-	-2.108	0.432	-32

Table 16: Cross-section 1 at the natural barrier

Augur Nr	Distance (m)	Height soil (m)	Height water table (m)	Height rock (m)	Distance between rock and surface level (m)	Angle with reference line (°)
13	3.7	-1.998	-	-1.998	0.000	29
14	4.4	-1.998	-	-2.577	0.579	29
15	6.7	-1.890	-3.020	-	-	29
16	9.4	-1.836	-2.897	-	-	29
17	11.2	-2.152	-3.538	-	-	209
18	14.7	-1.856	-3.010	-	-	29
19	16.5	-1.880	-2.983	-	-	29
20	20.3	-2.243	-	-3.403	1.160	209
21	38.2	-2.360	-	-4.215	1.855	209
22	51	-2.505	-4.680	-5.675	3.170	209

Table 17: Cross-section 2 at the natural barrier

Augur Nr	Distance (m)	Height soil (m)	Height water table (m)	Height rock (m)	Distance between rock and surface level (m)	Angle with reference line (°)
19	11.2	2.152	3.538	-	-	209
23	15	2.103	-	3.062	0.959	186
24	19.1	2.118	3.532	3.723	1.605	175
25	25.1	2.101	-	3.102	1.001	167
26	30.1	2.242	-	2.242	0	163

Table 18: Cross-section 3 at the natural barrier

Augur Nr	Distance (m)	Height soil (m)	Height water table (m)	Height rock (m)	Distance between rock and surface level (m)	Angle with reference line (°)
20	20.3	2.243	-	3.403	1.16	209
27	22.9	2.198	-	3.166	0.968	195
28	28.5	2.295	-	3.246	0.951	182

Table 19: Cross-section 4 at the natural barrier

Augur Nr	Distance (m)	Height soil (m)	Height water table (m)	Height rock (m)	Distance between rock and surface level (m)	Angle with reference line (°)
	92	2.950	4.720	-	-	231

Table 20: Scoop hole downstream of the natural barrier

In Table 21, the reference points 2 and 3 are measured into the already known river profile. Reference 3 is the place where the spirit level is usually standing. Reference point 2 is used for determining the height of the spirit level. The line between these two points is called a reference line, through which the further measured points are known.

Distance (m)	Height surface level (m)	Fall surface level (m)	Angle (°)	Remarks
Height rock R.P.4		0.817		
Height S.L		1.625		
65	1.09	0.535	-56	Angle with reference line punt 4-5
73	2.19			
54.4	1.132	1.058	2	
34	2.015			
13	1.521	0.494	27	
18.2	2.19			Reference point 3
17.5	1.77	0.42	32	Reference point 2

Table 21: Creating reference point by measuring from reference point at proposed site to natural barrier

The points in the table below are all taken from reference point 5. The angle is also taken from reference point 5 where the spirit level was standing, the angle is considered positive in the left turn.

Point Nr.	Distance (m)	Angle (°)	Height (m)
1	1.6	318	1.612
2	3.3	346	1.607
3	5.3	4	1.577
4	5.8	9	1.607
5	6.4	5	1.545
6	7.1	0	1.552
7	11.2	5	1.480
8	1.9	122	1.587
9	2.9	115	1.561
10	4.2	86	1.693
11	5.2	81	1.697
12	9	50	1.659
13	10	95	1.559
14	16.3	110	1.590
15	23	120	2.632
16	31.1	128	1.740
17	33.6	130	1.753
18	38.5	135	1.805
19	45	138	1.855
20	54.5	146	0.197
21	67	152	2.045
22	58	169	2.070
23	45	170	1.945
24	35.3	175	1.825
25	20.6	190	1.675
26	10.1	245	1.562
27	16	285	1.472
28	24.8	297	1.365
29	34	298	1.290
30	54	303	1.150
31	65	299	1.050
32	70	310	1.125
33	72	315	1.245
34	42.6	318	1.332
35	31	347	1.440
36	21.2	340	1.390
37	14.2	353	1.493
38	13.9	359	1.462
39	65	300	1.030
40	74	301	0.990
41	74.5	309.5	1.070
42	62.5	313.5	1.200

Table 22: Rotation method used at the proposed dam site

Point Nr.	GPS East		GPS South	
	Degrees	Minutes	Degrees	Minutes
1	038°	10,876'	01°	42,138'
2	038°	10,860'	01°	42,106'
3	038°	10,853'	01°	42,090'
4	038°	10,846'	01°	42,080'
5	038°	11,149'	01°	41,893'
6	038°	11,281'	01°	41,931'
7	038°	11,300'	01°	41,991'
8	038°	11,317'	01°	41,999'
9	038°	11,346'	01°	42,007'
10	038°	11,375'	01°	42,019'
11	038°	11,400'	01°	42,005'
12	038°	11,462'	01°	42,145'
13	038°	11,463'	01°	42,237'
14	038°	11,481'	01°	42,311'
15	038°	11,422'	01°	42,241'
16	038°	10,966'	01°	42,354'
17	038°	11,144'	01°	41,893'
18	038°	10,925'	01°	42,222'
19	038°	10,936'	01°	42,259'
20	038°	10,948'	01°	42,274'
21	038°	10,955'	01°	42,299'
22	038°	10,968'	01°	42,373'
23	038°	10,988'	01°	42,409'
24	038°	11,026'	01°	42,431'
25	038°	11,054'	01°	42,441'
26	038°	11,054'	01°	42,466'
27	038°	11,079'	01°	42,515'
28	038°	11,085'	01°	42,542'
29	038°	11,063'	01°	42,624'
30	038°	11,090'	01°	42,687'
31	038°	11,160'	01°	42,725'
32	038°	11,226'	01°	42,760'
33	038°	11,315'	01°	42,935'
34	038°	11,501'	01°	42,919'
35	038°	11,516'	01°	42,945'
36	038°	11,540'	01°	42,946'
37	038°	11,575'	01°	42,764'

Table 23: GPS positions of the catchment

Point Nr.	GPS East		GPS South	
	Degrees	Minutes	Degrees	Minutes
38	038°	11,234'	01°	41,958'
39	038°	11,230'	01°	41,971'
40	038°	11,239'	01°	41,988'
41	038°	11,269'	01°	42,020'
42	038°	11,281'	01°	42,016'
43	038°	11,291'	01°	42,035'
44	038°	11,294'	01°	42,033'
45	038°	11,316'	01°	42,036'
46	038°	11,344'	01°	42,059'
47	038°	11,328'	01°	42,095'
48	038°	11,321'	01°	42,129'
49	038°	11,340'	01°	42,155'
50	038°	11,368'	01°	42,205'
51	038°	11,359'	01°	42,236'
52	038°	11,375'	01°	42,157'
53	038°	11,357'	01°	42,122'
54	038°	11,365'	01°	42,102'
55	038°	11,332'	01°	42,099'
56	038°	11,257'	01°	42,027'
57	038°	11,259'	01°	41,987'
58	038°	11,257'	01°	41,987'
59	038°	11,119'	01°	41,984'
60	038°	11,104'	01°	42,000'
61	038°	11,104'	01°	42,018'
62	038°	11,102'	01°	42,046'
63	038°	11,100'	01°	42,066'
64	038°	11,111'	01°	42,082'
65	038°	11,115'	01°	42,104'
66	038°	11,103'	01°	42,110'
67	038°	11,107'	01°	42,124'
68	038°	11,104'	01°	42,134'
69	038°	11,094'	01°	42,145'
70	038°	11,105'	01°	42,159'
71	038°	11,113'	01°	42,167'
72	038°	11,111'	01°	42,170'
73	038°	11,125'	01°	42,192'
74	038°	11,127'	01°	42,196'
75	038°	11,141'	01°	42,208'
76	038°	11,106'	01°	42,169'
77	038°	11,092'	01°	42,188'
78	038°	10,986'	01°	42,124'

Table 24: GPS positions of the side streams

Appendix V: Tables groundwater research

The first three samples were taken 60 meters upstream of the Kamunyuni dam in the middle of the riverbed at a depth of 0.5 meters. All this samples were done in the same tube with the length of $H=39.6$ cm

sample 1(L=4.6 cm)					
t (sec)	x (cm)	H	h1	h1/H	ln(h1/H)
0	0.00	39.60	39.60	1.00	0.00
19	1.00	39.60	38.60	0.97	-0.03
42	2.00	39.60	37.60	0.95	-0.05
65	3.00	39.60	36.60	0.92	-0.08
94	4.00	39.60	35.60	0.90	-0.11
115	5.00	39.60	34.60	0.87	-0.13
149	6.00	39.60	33.60	0.85	-0.16
179	7.00	39.60	32.60	0.82	-0.19
211	8.00	39.60	31.60	0.80	-0.23
246	9.00	39.60	30.60	0.77	-0.26
285	10.00	39.60	29.60	0.75	-0.29
322	11.00	39.60	28.60	0.72	-0.33
361	12.00	39.60	27.60	0.70	-0.36
405	13.00	39.60	26.60	0.67	-0.40
441	14.00	39.60	25.60	0.65	-0.44
488	15.00	39.60	24.60	0.62	-0.48
535	16.00	39.60	23.60	0.60	-0.52
588	17.00	39.60	22.60	0.57	-0.56
638	18.00	39.60	21.60	0.55	-0.61
697	19.00	39.60	20.60	0.52	-0.65
754	20.00	39.60	19.60	0.49	-0.70
808	21.00	39.60	18.60	0.47	-0.76
889	22.00	39.60	17.60	0.44	-0.81
970	23.00	39.60	16.60	0.42	-0.87
1049	24.00	39.60	15.60	0.39	-0.93
1133	25.00	39.60	14.60	0.37	-1.00
1221	26.00	39.60	13.60	0.34	-1.07
1331	27.00	39.60	12.60	0.32	-1.15
1449	28.00	39.60	11.60	0.29	-1.23
1539	29.00	39.60	10.60	0.27	-1.32
1720	30.00	39.60	9.60	0.24	-1.42
1840	31.00	39.60	8.60	0.22	-1.53
1989	32.00	39.60	7.60	0.19	-1.65
2160	33.00	39.60	6.60	0.17	-1.79
2319	34.00	39.60	5.60	0.14	-1.96
2425	35.00	39.60	4.60	0.12	-2.15

Table 25: Results from permeability test from sample 1 with $L=4.6$ cm and $H=39.6$ cm

sample 2 (L=4.3 cm)					
t (sec)	x (cm)	H	h2	h2/H	ln(h2/H)
0	0.00	39.60	39.60	1.00	0.00
57	1.00	39.60	38.60	0.97	-0.03
128	2.00	39.60	37.60	0.95	-0.05
210	3.00	39.60	36.60	0.92	-0.08
313	4.00	39.60	35.60	0.90	-0.11
419	5.00	39.60	34.60	0.87	-0.13
587	6.00	39.60	33.60	0.85	-0.16
720	7.00	39.60	32.60	0.82	-0.19
906	8.00	39.60	31.60	0.80	-0.23
1106	9.00	39.60	30.60	0.77	-0.26
1317	10.00	39.60	29.60	0.75	-0.29
1555	11.00	39.60	28.60	0.72	-0.33
1809	12.00	39.60	27.60	0.70	-0.36
2073	13.00	39.60	26.60	0.67	-0.40
2326	14.00	39.60	25.60	0.65	-0.44
2697	15.00	39.60	24.60	0.62	-0.48
3173	16.00	39.60	23.60	0.60	-0.52

Table 26: Results from permeability test from sample 2 with L=4.3 cm and H=39.6 cm

Sample 3 (L=6.0 cm)					
t (sec)	x (cm)	H	h3	h3/H	ln(h3/H)
0	0.00	39.60	39.60	1.00	0.00
2	1.9	39.60	37.70	0.95	-0.05
3	2.7	39.60	36.90	0.93	-0.07
4	4.0	39.60	35.60	0.90	-0.11
5	4.7	39.60	34.90	0.88	-0.13
6	5.3	39.60	34.30	0.87	-0.14
7	6.0	39.60	33.60	0.85	-0.16
8	6.7	39.60	32.90	0.83	-0.19
9	7.4	39.60	32.20	0.81	-0.21
10	7.9	39.60	31.70	0.80	-0.22
11	8.6	39.60	31.00	0.78	-0.24
12	9.2	39.60	30.40	0.77	-0.26
13	9.7	39.60	29.90	0.76	-0.28
14	10.4	39.60	29.20	0.74	-0.30
15	10.8	39.60	28.80	0.73	-0.32
16	11.2	39.60	28.40	0.72	-0.33
17	11.7	39.60	27.90	0.70	-0.35
18	12.0	39.60	27.60	0.70	-0.36
19	12.5	39.60	27.10	0.68	-0.38
20	13.0	39.60	26.60	0.67	-0.40
21	13.2	39.60	26.40	0.67	-0.41
22	13.3	39.60	26.30	0.66	-0.41
23	13.8	39.60	25.80	0.65	-0.43
24	13.9	39.60	25.70	0.65	-0.43
25	14.4	39.60	25.20	0.64	-0.45
26	14.6	39.60	25.00	0.63	-0.46
27	14.9	39.60	24.70	0.62	-0.47
28	15.3	39.60	24.30	0.61	-0.49

Table 27: Results from permeability test from sample 3 with L=6.0 cm and H=39.6 cm

	sample 4	sample 5	sample 6	sample 7	sample 8	sample 9
	Tube 1	Tube 2	Tube 3	Tube 4	Tube 5	Tube 6
	L4=5.2 cm	L5=7.4 cm	L6=7.0 cm	L7=9.9 cm	L8=6.5 cm	L9=4.2 cm
	H1=31.2 cm	H2=31.4 cm	H3=30.3 cm	H4=30.0 cm	H5=32.0 cm	H6=21.9 cm
t (min)	x (cm)	x (cm)	x (cm)	x (cm)	x (cm)	x (cm)
0.00	0.00	0.00	0.00	0.00	0.00	0.00
3.00	*	2.9	2.6	1.6	1.90	7.80
6.00		5.1	4.8	3.5	3.50	12.60
9.00		7.7	7.0	5.4	5.00	*
12.00		9.8	8.7	7.0	6.50	
15.00		11.7	10.8	8.6	7.50	
18.00		13.4	12.2	9.9	9.00	
21.00		15.0	13.5	11.0	10.20	
24.00		16.5	14.8	12.30	11.40	
27.00		17.3	16.1	13.50	12.00	
30.00		18.5	17.5	14.50	13.00	
33.00		19.8	18.7	15.50	13.90	
36.00		20.4	19.4	16.20	14.90	
39.00		21.9	19.9	17.20	15.60	
42.00		22.6	20.9	17.70	16.60	
45.00			22.0	18.80	17.30	
48.00				19.60	18.00	
51.00					18.60	
54.00					19.60	
57.00					19.90	
60.00					20.90	
63.00					21.20	
66.00					21.70	
69.00					22.10	
72.00					22.90	
75.00					23.50	
78.00					23.80	
81.00					24.30	

Table 28: Results permeability tests from the samples 4-9

$\ln(h_4/H_1)$	$\ln(h_5/H_2)$	$\ln(h_6/H_3)$	$\ln(h_7/H_4)$	$\ln(h_8/H_5)$	$\ln(h_9/H_6)$
0.00	0.00	0.00	0.00	0.00	0.00
*	-0.10	-0.09	-0.05	-0.06	-0.44
	-0.18	-0.17	-0.12	-0.12	-0.86
	-0.28	-0.26	-0.20	-0.17	
	-0.37	-0.34	-0.27	-0.23	
	-0.47	-0.44	-0.34	-0.27	
	-0.56	-0.52	-0.40	-0.33	
	-0.65	-0.59	-0.46	-0.38	
	-0.75	-0.67	-0.53	-0.44	
	-0.80	-0.76	-0.60	-0.47	
	-0.89	-0.86	-0.66	-0.52	
	-1.00	-0.96	-0.73	-0.57	
	-1.05	-1.02	-0.78	-0.63	
	-1.20	-1.07	-0.85	-0.67	
	-1.27	-1.17	-0.89	-0.73	
		-1.29	-0.99	-0.78	
			-1.06	-0.83	
				-0.87	
				-0.95	
				-0.97	
				-1.06	
				-1.09	
				-1.13	
				-1.17	
				-1.26	
				-1.33	
				-1.36	
				-1.42	

Table 29: Calculation results from the samples 4-9

	Sample 10	Sample 11	Sample 12	Sample 13	Sample 14	Sample 15
	Tube 1	Tube 3	Tube 3	Tube 3	Tube 3	Tube 3
	L10=6.8 cm	L11=4.8 cm	L12=5.8 cm	L13=5.3 cm	L14=3.4 cm	L15=5.2 cm
	H1=31.2 cm	H3=30.3 cm	H3=30.3 cm	H3=30.3 cm	H3=30.3 cm	H3=30.3 cm
t (sec)	x (cm)	x (cm)	x (cm)	x (cm)	x (cm)	x (cm)
10.00	0.00	0.00	0.00	0.00	0.00	0.00
20.00	2.00	1.60	2.50	1.30	3.50	1.40
30.00	3.00	2.70	5.00	2.90	6.00	2.80
40.00	4.60	3.80	7.10	4.20	8.30	4.70
50.00	5.60	4.90	8.90	5.60	10.20	5.70
60.00	6.90	6.00	10.60	6.70	11.60	6.60
70.00	8.10	6.90	12.10	7.80	12.90	7.80
80.00	9.20	7.80	13.60	8.70	14.20	8.90
90.00	10.30	8.60	14.60	9.70	15.40	10.30
100.00	11.10	9.00	16.00	10.50	16.40	10.70
110.00	12.00	10.10	17.00	11.30	17.30	11.60
120.00	12.70	10.90	18.00	12.00	18.00	12.50
130.00	13.40	11.70	18.90	12.80	18.90	13.40
140.00	14.00	12.60	19.90	13.50	19.60	14.20
150.00	14.70	12.90	20.70	14.10	20.20	14.80
160.00	15.50	13.50	21.50	14.70	20.70	15.40
170.00	15.90	14.30	22.10	15.30	21.10	16.30
180.00	16.10	14.70	22.70	16.00	21.70	16.90
190.00	16.90	15.30	23.40	16.50	22.10	17.30
200.00	17.50	15.90	24.00	16.90	22.70	17.60
210.00	18.10	16.20		17.50	23.00	18.20
220.00	18.50	16.60		18.10	23.80	18.90
230.00	18.80	17.00		18.60	24.00	19.20
240.00	19.20	17.30		19.00	24.60	19.50
250.00	19.70	17.70		19.40	25.20	19.90
260.00	20.10	18.20		19.80	25.50	20.20
270.00	20.40	18.60		20.30		20.60
280.00	20.90	18.90		20.70		20.90
290.00	21.20	19.40		21.00		21.10
300.00	21.50	19.70		21.50		21.30
310.00	21.90	20.10		21.80		21.80
320.00	22.20	20.30		22.20		22.10
330.00	22.80	20.60		22.50		22.30
340.00	23.00	21.20		22.80		22.60
350.00	23.30	21.50		23.10		23.00
360.00	23.60	21.80		23.40		23.40
370.00	24.00	22.00		23.70		
380.00		22.40		23.90		
390.00		22.50		24.10		
400.00		22.80		24.40		
410.00		23.10		24.70		

Table 30: Results permeability tests from the samples 10-15

$\ln(h_{10}/H_1)$	$\ln(h_{11}/H_3)$	$\ln(h_{12}/H_3)$	$\ln(h_{13}/H_3)$	$\ln(h_{14}/H_3)$	$\ln(h_{15}/H_3)$
0	0	0	0	0	0
-0.06625	-0.05425	-0.08611	-0.04385	-0.12275	-0.04731
-0.1011	-0.09333	-0.18034	-0.1006	-0.22067	-0.09696
-0.15951	-0.134	-0.267	-0.14921	-0.32011	-0.16856
-0.19783	-0.1764	-0.34776	-0.20434	-0.41043	-0.2084
-0.24994	-0.22067	-0.43053	-0.2499	-0.48262	-0.24567
-0.30059	-0.25841	-0.50973	-0.29763	-0.55468	-0.29763
-0.34938	-0.29763	-0.59574	-0.33845	-0.63233	-0.34776
-0.40067	-0.33384	-0.65749	-0.38586	-0.70979	-0.41542
-0.4397	-0.35244	-0.75089	-0.42547	-0.77926	-0.43562
-0.48551	-0.40547	-0.82338	-0.46671	-0.8462	-0.48262
-0.52265	-0.44587	-0.90155	-0.50425	-0.90155	-0.53195
-0.56122	-0.48799	-0.97753	-0.54895	-0.97753	-0.58383
-0.59551	-0.53758	-1.06934	-0.58977	-1.0409	-0.63233
-0.63706	-0.55468	-1.14938	-0.62614	-1.09861	-0.67031
-0.68676	-0.58977	-1.2364	-0.66388	-1.14938	-0.70979
-0.71257	-0.63856	-1.30701	-0.7031	-1.19194	-0.77209
-0.72572	-0.66388	-1.383	-0.75089	-1.25939	-0.81589
-0.78016	-0.7031	-1.47963	-0.78648	-1.30701	-0.8462
-0.82302	-0.74392	-1.5706	-0.81589	-1.383	-0.86955
-0.86781	-0.76497		-0.8617	-1.42327	-0.91794
-0.89882	-0.79375		-0.90971	-1.53935	-0.97753
-0.92272	-0.82338		-0.95156	-1.5706	-1.0042
-0.95551	-0.8462		-0.98634	-1.67068	-1.0316
-0.99807	-0.87745		-1.02238	-1.78191	-1.06934
-1.03347	-0.91794		-1.05977	-1.84253	-1.09861
-1.06087	-0.95156		-1.10856		-1.13902
-1.10827	-0.97753		-1.14938		-1.17044
-1.13783	-1.02238		-1.18113		-1.19194
-1.16829	-1.05029		-1.2364		-1.21392
-1.2104	-1.08876		-1.27108		-1.27108
-1.24319	-1.10856		-1.31928		-1.30701
-1.31219	-1.13902		-1.35702		-1.33171
-1.33628	-1.20287		-1.39624		-1.36993
-1.37356	-1.2364		-1.43707		-1.42327
-1.41227	-1.27108		-1.47963		-1.47963
-1.46634	-1.29489		-1.52408		
	-1.34428		-1.55485		
	-1.35702		-1.5866		
	-1.39624		-1.6362		
	-1.43707		-1.68838		

Table 31: Calculation results from the permeability tests from the samples 10-15

	Sample 16	Sample 17	Sample 18	Sample 19	Sample 20	Sample 21
	Tube 1	Tube 2	Tube 3	Tube 4	Tube 5	Tube 6
	L16=5.3 cm	L17=5.4 cm	L18=6.0 cm	L19=3.2 cm	L20=6.1 cm	L21=4.8 cm
	H1=31.2 cm	H2=31.4 cm	H3=30.3 cm	H4=30.0 cm	H5=32.0 cm	H6=21.9 cm
t (min)	x (cm)	x (cm)	x (cm)	x (cm)	x (cm)	x (cm)
0.00	0.00	0.00	0.00	0.00	0.00	0.00
10.00	0.50	0.20	0.10	0.20	0.20	0.30
20.00	1.00	0.30	0.30	0.60	1.20	1.50
30.00	1.90	0.40	0.30	1.10	1.90	2.40
60.00	4.10	1.60	1.20	2.00	3.50	4.60
90.00	6.20	2.50	2.20	3.00	5.80	6.40
120.00	7.70	2.90	2.60	3.30	6.60	8.00
150.00	9.20	3.90	3.10	4.50	8.20	9.40
210.00	12.30	5.00	4.00	5.40	10.20	12.10
270.00	14.90	6.30	4.80	6.70	12.50	14.00
330.00	17.30	7.10	5.60	8.10	14.10	16.10
390.00	19.70	8.10	6.30	9.00	15.60	
510.00	22.90	10.20	7.80	11.70	18.50	
570.00	24.00	11.50	8.50	12.00	20.10	
630.00		12.70	8.60	13.10	20.70	
1230.00		19.40	13.30	19.60		
1350.00		20.80	13.90	20.20		

Table 32: Results from permeability tests from the samples 16-21

$\ln(h_{16}/H_1)$	$\ln(h_{17}/H_2)$	$\ln(h_{18}/H_3)$	$\ln(h_{19}/H_4)$	$\ln(h_{20}/H_5)$	$\ln(h_{21}/H_6)$
0.00	0.00	0.00	0.00	0.00	0.00
-0.02	-0.01	0.00	-0.01	-0.01	-0.01
-0.03	-0.01	-0.01	-0.02	-0.04	-0.07
-0.06	-0.01	-0.01	-0.04	-0.06	-0.12
-0.14	-0.05	-0.04	-0.07	-0.12	-0.24
-0.22	-0.08	-0.08	-0.11	-0.20	-0.35
-0.28	-0.10	-0.09	-0.12	-0.23	-0.45
-0.35	-0.13	-0.11	-0.16	-0.30	-0.56
-0.50	-0.17	-0.14	-0.20	-0.38	-0.80
-0.65	-0.22	-0.17	-0.25	-0.50	-1.02
-0.81	-0.26	-0.20	-0.31	-0.58	-1.33
-1.00	-0.30	-0.23	-0.36	-0.67	
-1.32	-0.39	-0.30	-0.49	-0.86	
-1.47	-0.46	-0.33	-0.51	-0.99	
	-0.52	-0.33	-0.57	-1.04	
	-0.96	-0.58	-1.06		
	-1.09	-0.61	-1.12		

Table 33: Calculation results from the permeability tests from the samples 16-21

The tubes used with samples 22-26 have other lengths than the ones used earlier.

	Sample 22	Sample 23		Sample 24	Sample 25	Sample 26
	Tube 1	Tube 2		Tube 3	Tube 4	Tube 5
	L22=4 cm	L23=5.5 cm		L24=5.9 cm	L25=6.3 cm	L26=6.2 cm
	H1=31 cm	H2=30.5 cm		H3=31.6 cm	H4=29.9 cm	H5=31.5 cm
t (min)	x (cm)	x (cm)	t (min)	x (cm)	x (cm)	x (cm)
0.00	0.00	0.00	0.00	0.00	0.00	0.00
10.00	0.10	0.10	30.00	1.40	1.40	0.70
20.00	0.10	0.30	60.00	2.10	2.80	1.40
30.00	0.20	0.60	90.00	2.90	3.80	1.80
40.00	unreliable	1.00	120.00	4.00	4.90	2.00
50.00	clogged	1.30	150.00	4.70	5.80	2.30
60.00		1.60	180.00	5.30	6.90	2.40
90.00		2.90	210.00	6.40	7.90	2.90
120.00		4.20	240.00	6.80	9.10	3.20
150.00		6.00	270.00	7.70	9.50	4.00
180.00		7.20	300.00	8.20	10.10	4.10
210.00		8.20	330.00	8.30	10.90	4.40
240.00		9.30	360.00	9.00	11.80	4.60
270.00		10.00	390.00	10.30	12.50	5.30
300.00		11.30	420.00	11.10	13.70	5.80
330.00		12.40	450.00	12.10	14.30	6.60
360.00		15.00	480.00	12.90	15.50	7.00
390.00		22.00	510.00	13.50	16.50	7.30

Table 34: Results permeability tests from samples 21-26

$\ln(h_{22}/H_1)$	$\ln(h_{23}/H_2)$	$\ln(h_{24}/H_3)$	$\ln(h_{25}/H_4)$	$\ln(h_{26}/H_5)$
0.00	0.00	0.00	0.00	0.00
0.00	0.00	-0.05	-0.05	-0.02
0.00	-0.01	-0.07	-0.10	-0.05
-0.01	-0.02	-0.10	-0.14	-0.06
	-0.03	-0.14	-0.18	-0.07
	-0.04	-0.16	-0.22	-0.08
	-0.05	-0.18	-0.26	-0.08
	-0.10	-0.23	-0.31	-0.10
	-0.15	-0.24	-0.36	-0.11
	-0.22	-0.28	-0.38	-0.14
	-0.27	-0.30	-0.41	-0.14
	-0.31	-0.30	-0.45	-0.15
	-0.36	-0.34	-0.50	-0.16
	-0.40	-0.39	-0.54	-0.18
	-0.46	-0.43	-0.61	-0.20
	-0.52	-0.48	-0.65	-0.24
	-0.68	-0.52	-0.73	-0.25
	-1.28	-0.56	-0.80	-0.26

Table 35: Calculation results from the permeability tests from the samples 21-26

Appendix VI: Rain gauge form

The amount will be measured in milliliters, the depth can then be calculated using the area of the top of the rain gauge.

Day	Date	Amount (ml)	Depth rain (mm)
Sunday	22-Jun-03		
Monday	23-Jun-03		
Tuesday	24-Jun-03		
Wednesday	25-Jun-03		
Thursday	26-Jun-03		
Friday	27-Jun-03		
Saturday	28-Jun-03		
Sunday	29-Jun-03		
Monday	30-Jun-03		
Tuesday	1-Jul-03		
Wednesday	2-Jul-03		
Thursday	3-Jul-03		
Friday	4-Jul-03		
Saturday	5-Jul-03		
Sunday	6-Jul-03		
Monday	7-Jul-03		
Tuesday	8-Jul-03		
Wednesday	9-Jul-03		
Thursday	10-Jul-03		
Friday	11-Jul-03		
Saturday	12-Jul-03		

Table 36: Form for collecting rainfall data, supplied to the Kisayani primary school

Appendix VIII: Overview Ngungu River at the two locations

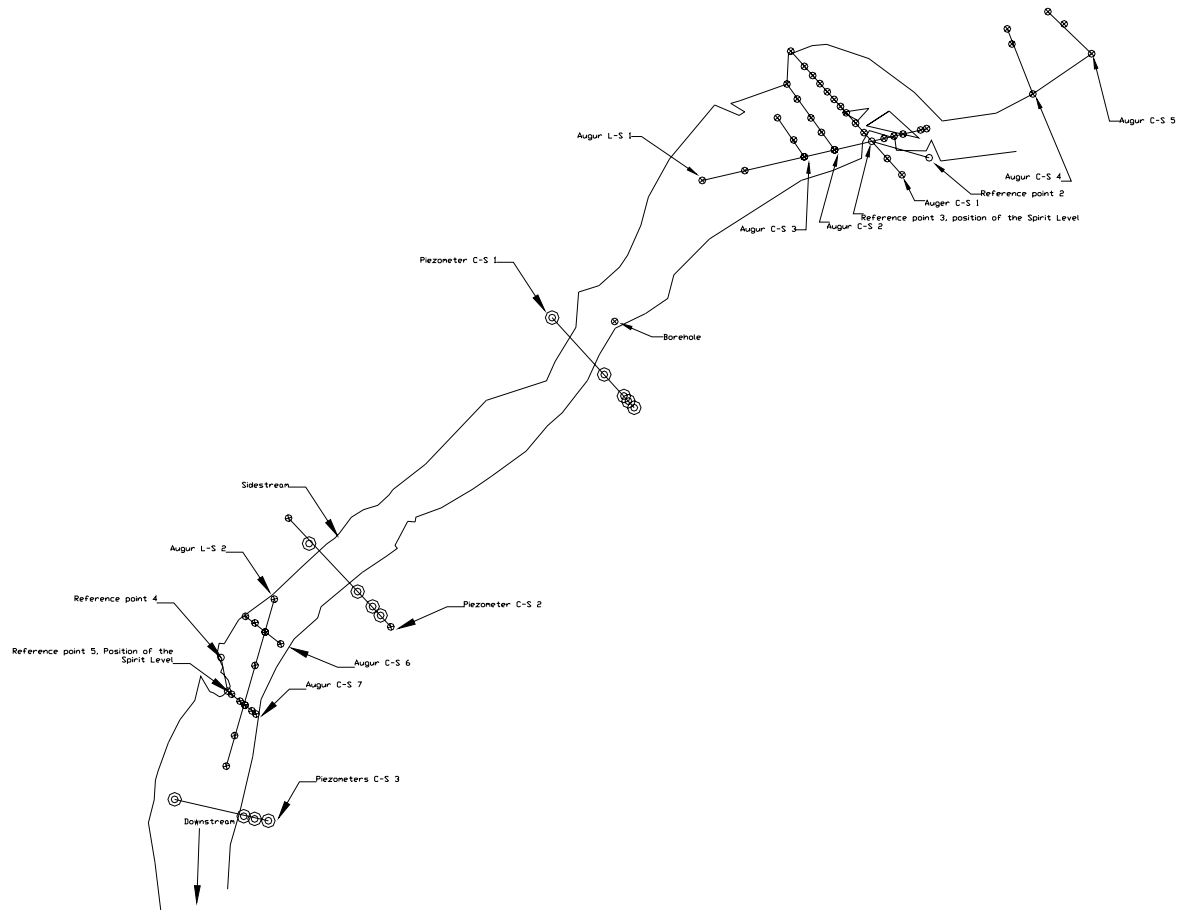

Appendix IX: Map of Kitui south